

# **Annual Report**

**2016**

**2017**

**IOM-NCGM  
Research Collaboration Office**

**February 2018  
Kathmandu, Nepal  
Tokyo, Japan**





# Annual Report

2016

2017

**IOM-NCGM**

**Research Collaboration Office**



**February 2018**

**Kathmandu, Nepal**

**Tokyo, Japan**





## Preface

The Medical Education Project, which was implemented from 1980 to 1996, contributed to the establishment and enhancement of basic and the clinical medicine of the Institute of Medicine (IOM) at Tribhuvan University along with its attached teaching hospital (TUTH). During the project period experts dispatched from NCGM worked together with IOM staff and good relationship was built between the two institutions.

After the completion of the project IOM achieved further development and currently it is greatly contributing to medical education, medical care, researches and human resource development in Nepal. Besides, reliable relationship between NCGM and IOM has been maintained until today. This is one of the valuable outcomes and legacies of the project.

In January 2013, Memorandum of Understanding (MOU) was concluded between NCGM and IOM to start a unique cooperation focusing on research and related human resource development. Five years have passed since the start of the new cooperation between NCGM and IOM. Collaborations initiated based on the MOU are on track, and a number of fruitful outcomes have been obtained.

It is a great pleasure for us to summarize the report of our new collaboration as Annual Report 2016-17 following the publications of Annual Report 2013, 2014 and 2015. We also would like to thank all those who worked hard for the success of the project and toward the realization of new collaborations between NCGM and IOM. I sincerely hope that the relationship of mutual trust between the two institutions will be further strengthened.



**Hiroshi Ohara, M.D.,Ph.D.**

Director, Division of Global Networking,  
Bureau of International Health Cooperation,  
National Center for Global Health and Medicine  
Tokyo, Japan



Tribhuvan University  
Institute of Medicine  
Maharajgunj Medical Campus

 { 4-418672  
4-422973  
4-422971  
4-418482  
Fax: 977-1-4423771

Post Box No.: 1524  
Maharajgunj, Kathmandu, Nepal

Date : .....

Ref. No. :

January 12, 2018

### Preface

It gives us immense pleasure that Dr. Hiroshi Ohara has contributed to develop the Annual Report of National Center for Global Health and Medicine (NCGM) 2016-2017. In this regards, we would like to express our congratulations to Dr. Ohara and his team for their efforts and dedication. NCGM has been playing great role to strengthen the research capacity and additional component for the research of Institute of Medicine (IOM) and Tribhuvan University Teaching Hospital (TUTH). As a result, several scientific articles of Medical researchers of NCGM and IOM have published in different journals of national and international.

The scientists of both institutions have well established close relationship to build up research collaboration and are conducting public health and biomedical research to strengthen understanding of medical science through their research.

We would like to express our sincere gratitude to NCGM mainly to Dr. Hiroshi Ohara.

With best wishes,

Prof. Dr. Bharat Mahi Pokhrel,  
Senior Researcher,  
Department of Microbiology and Research Laboratory

Prof. Dr. Jeevan B. Sherchand  
Head, Department of Microbiology  
and Research Laboratory



## Abbreviations

<b>AMR</b>	Antimicrobial Resistance
<b>ESBL</b>	Extended Stratum beta Lactamase
<b>GFATM</b>	Global Fund against AIDS, Tuberculosis and Malaria
<b>IOM</b>	Institute of Medicine
<b>JICA</b>	Japan International Cooperation Agency
<b>MBBS</b>	Medicine Bachelor Bachelor Surgery
<b>MOHP</b>	Ministry of Health and Population
<b>MOU</b>	Memorandum of Understanding
<b>NCD</b>	Non Communicable Diseases
<b>NCGM</b>	National Center for Global Health and Medicine
<b>NDM</b>	New Delhi Methalo- $\beta$ -Lactamase
<b>ODA</b>	Official Development Assistance
<b>TUTH</b>	Tribuban University Teaching Hospital
<b>WHO</b>	World Health Organization
<b>WPRO</b>	Western Pacific Regional Office



# Contents

## **Preface**

- 1. NCGM..... 03
- 2. IOM..... 04

## **Abbreviations..... 05**

## **Contents..... 06**

### **I. Outline of Collaboration between NCGM and IOM**

- 1. Background..... 07
- 2. Start of the new collaboration..... 08
- 3. Purpose of the collaboration between NCGM and IOM, and expected outcomes..... 09

### **II. Research activities**

- 1. Overview of researches..... 10
- 2. Visit to Nepal for a collaborative research on a subnational health impact of the 2015 Nepal earthquake..... 12
- Researches No.1- No.5..... 13
- List of papers published on international journals from 2012 to 2015:  
Achievement in NCGM-IOM Collaboration Office..... 18

## **Attachment: Scientific papers..... 21**



# I. Outline of Collaboration between NCGM and IOM

## 1. Background

The Institute of Medicine (IOM) at Tribhuvan University was established as the first medical school in Nepal with the support of Japan's Grant Aid in 1980 and then a technical cooperation project (Medical Education Project) was implemented from 1980 to 1996 supported by Japan International Cooperation Agency (JICA). During this period, the National Center for Global Health and Medicine (NCGM) dispatched project team leaders, doctors and other medical professionals.

The Medical Education Project was implemented as a technical cooperation project in two phases. In the first phase (1980-1989), strengthening education, clinical practice, and the research infrastructure for basic medicine and clinical medicine were mainly implemented. In the second phase (1989-1996), a technical guidance was conducted, focusing mainly on improving medical education to have international accreditation, enhancing the function of basic medicine, clinical medicine, and research, as well as improving hospital management function.

During the 16-year technical cooperation period almost all the basic and advanced techniques regarding diagnosis, examination, treatment and clinical record, which were indispensable to the daily medical care and medical education in IOM and its attached teaching hospital (Tribhuvan University Teaching Hospital; TUTH), were guided (however, nosocomial infection control was not included as awareness on it was still low in those days even in advanced countries). IOM/TUTH had grown to be a medical institution that carried out a kernel function of Nepalese medical care, and had gained extremely high reliance from Nepalese people.

After the completion of the project, IOM has been functioning as a core in medical education, medical care and medical human resource development in Nepal, and TUTH has gained the trust and popularity of the people in Nepal.

Nepal suffered political instability from 1996 to 2006 followed by a transition from the Kingdom of Nepal to the Federal Democratic Republic of Nepal in 2008. The political instability affected economic growth and compromised the delivery of social and public health interventions in the country. During this period, cooperative relations between IOM and NCGM were temporarily suspended, but with the stabilizing of political conditions, the good relationship resumed.



Medical Education Project in Nepal (JICA)

In September 2009, a joint symposium on nosocomial infection control was held at IOM organized by NCGM and IOM, resulting in a greater awareness of the importance of infection control and research collaboration. At the conference, successful technical cooperation in nosocomial infection control in Vietnam was introduced inviting director of Bach Mai Hospital in Hanoi.

## 2. Start of the new collaboration

On January 18, 2013, NCGM concluded an agreement of cooperation with IOM in Nepal for research and related human resource development, and IOM became the fifth overseas platform of NCGM. The Memorandum of Understanding (MOU) was signed by the President of NCGM in Tokyo firstly, and then, was signed by the Dean of IOM at IOM in the capital Kathmandu. Based on this MOU, unique activities of NCGM, such as collaborative research on infectious diseases, nosocomial infection, dual burden of infectious diseases and non-communicable diseases, and development of human resources related to these researches came to be actively promoted, seeking to improve healthcare in Nepal. Collaboration between NCGM and IOM including related institutions Kathmandu University School of Medicine, Clinics in Kathmandu, etc. mainly on research field has continued thereafter. Conclusion of MOU is considered to be highly effective for the smooth and efficient implementation of collaborations including related institutions.

In September 2013, the IOM-NCGM Research Collaboration Office was established in the academic building of IOM, and the necessary equipment (desk, chair, computer, projector and scanner) was installed. One assistant was employed and given an orientation. Initially, grants from the International Health Cooperation Research (24-5, 25-7), a grant from the Ministry of Health, Labor and Welfare of Japan, were used and thereafter some other grants have also been utilized to conduct various activities. IOM's Department of Microbiology and NCGM's Bureau of International Health Cooperation manage the office operation.

Following the ceremony of the MOU signing "the 1st Joint Conference on Infectious Diseases with Growing Concern in Recent Years in Nepal" was held at IOM on January 18, 2013 (the second conference was held in December 2014).



Signing of MOU at NCGM and IOM (January 2013)

### 3. Purpose of the collaboration between NCGM and IOM, and expected outcomes

The purpose of this collaboration is to contribute to the healthcare in both countries by collaborative research and related human resource development, and to strengthen a reliable relationship.

#### Expected Outcomes

1. To strengthen research activities by the publication and presentation at academic conferences, etc. of the collaborative researches between NCGM and IOM.
2. To obtain research results effectively through collaboration with IOM that is the main medical care and medical education institution in Nepal.
3. To provide benefits to younger staff members of NCGM by learning about the actual conditions of medical care in developing countries and how international collaborations are conducted.
4. To promote a relationship by utilizing a good relationship built on the results of the technical cooperation project.
5. To contribute to the quality improvement of medical care in Nepal by conducting researches focused on high-priority infectious diseases and other emerging health priorities in Nepal and providing related technical assistance. These results are also beneficial for medical care in Japan.
6. To enable wider range of cooperation in the future, because the inclusion of medical institutions other than IOM allows providing further possible collaboration fields.
7. To contribute to expansion of the benefit of the Japan's ODA projects.



IOM-NCGM Research Collaboration Office



## II. Research activities

### 1. Overview of researches

The main theme of the ongoing researches is “Infectious diseases with growing concern in recent years in Nepal.” In other words, “Emerging health priorities in infectious diseases in Nepal”. Infectious diseases change over time, as can be seen by the appearance of emerging or re-emerging infectious diseases, Antimicrobial Resistance (AMR), spread of drug-resistant malaria, etc. These changes are often associated with social and environmental factors including development, population movement, climate change, nutritional status, condition of health system, inappropriate use of antibiotics. Control strategy and assistance of foreign countries also affect infectious diseases.

Infectious diseases, which have growing issues in recent years in Nepal but appropriate studies along with control measures have not been done, are target of these researches. These researches are aiming to analyze the latest situation of the target infectious diseases and the causative factors of growing issues. Such analysis is crucial to implement effective control.

➤ As a result of preliminary survey and a series of discussion in our research team (both Japanese and Nepalese), we recognized that the following topics were suitable in consideration of the concept of the main theme and feasibility.

- ① AMR
- ② Healthcare associated infections (Nosocomial infection)
- ③ Dual burden of infectious diseases and non-communicable diseases
- ④ Viral hepatitis
- ⑤ Malaria control and health system
- ⑥ Diarrhea caused by emerging pathogens

Among them researches on ①,②,③,④ have been conducted up to 2017. Researches ⑤,⑥ were conducted in 2013-15 and these researches have already concluded by the end of 2015. (Cf. Annual reports 2013, 2014, 2015)

<http://www.ncgm.go.jp/kyokuhp/library/annual/index.html>

- Outline of each research which was conducted in 2016-17 is shown in on pages 13-17.
- List of scientific papers which were published on international journals as a result of collaborative studies during the period from 2012 to 2017 are shown on pages 18-20.
- As the published papers show, we have already made some valuable achievements. Among them it is

noteworthy that 3 new NDM variants were discovered from the nosocomial infection cases and named NDM-8, 12 and 13. Including these discoveries it was revealed that in medical settings in Nepal, AMR particularly in gram negative bacilli were spreading and it was suggested that immediate countermeasures are needed.

➤ To implement collaborative activities and strengthen the IOM-NCGM Research Collaboration Office, the following grants were utilized in 2016-2017.

- Grants from the International Health Cooperation Research, grants from the Ministry of Health, Labor and Welfare of Japan (25-5, 25-7, 27-4, 29-5).
- Clinical Epidemiology Research, St. Luke's International University, Tokyo, Japan (2016)
- Grant-in-Aid for Scientific Research (B) (Overseas Academic Research) from Japan Society for the Promotion of Science to NM

➤ NCGM planned a new research proposal on the health impact of the 2015 Nepal earthquake (Cf. page 10). This topic is one of the emerging health priorities in Nepal. Hereafter the main theme will be widened from “Emerging health priorities in infectious diseases in Nepal” to “Emerging health priorities in Nepal”.



Training course on nosocomial infection control for newly recruited nurses (TUTH)



Internal Medicine Ward (TUTH)

## 2. Visit to Nepal for a collaborative research on a subnational health impact of the 2015 Nepal earthquake

**Date:** September, 20–24th, 2017

**Visitors:** Hidechika Akashi<sup>1</sup>, Yoko Iwaki<sup>2</sup>, Kazuki Miyazaki<sup>1</sup>, Shuhei Nomura<sup>2</sup>, Hiroshi Ohara<sup>1</sup>, Manami Uechi<sup>2</sup>

1. Department of Global Network and Partnership, Bureau of International Health Cooperation, National Center for Global Health and Medicine
2. Institute for Global Health Policy Research, Bureau of International Health Cooperation

A 7.8 magnitude earthquake struck Nepal on April 2015, causing massive damage on Kathmandu and other nearby areas. Institute for Global Health Policy Research (iGHP) in NCGM will launch the collaborative research with Nepal's Institute of Medicine (IOM), Tribhuvan University Teaching Hospital, with the aim to understand the potential medium to long-term health impact of the earthquake at subnational, district level in order to inform the creation of disaster resilient regional health system after a major disaster, including earthquake.



With logistics and administrative support from the Bureau of International Health Cooperation, we visited Nepal (in particular the IOM) in September 20–24th, 2017. The purposes of the visit were:

1. to coordinate the research governance by gaining agreement on the research proposal with the principle researchers from the IOM
2. to discuss the arrangement of data access (the Annual Report of the Department of Health Service, Ministry of Health and Population, Nepal), identifying administrative division/persons of the data
3. to confirm the approval process and necessary materials for research ethics in the country
4. to conduct an inspection of the most affected area (Bhaktapur), where the damage of the earthquake was the greatest

During the 4-day visit in Nepal, we have confirmed the concrete direction of the research activities with the IOM, including data access and ethics approval. In addition, we shared the experience of Japan's 2011 Great East Earthquake with the 15 researchers from IOM (photo above).

## Research No.1

1.	<b>Title(in English)</b>	Study on effective use of the surveillance results for drug resistant pathogens in nosocomial infection control
2.	<b>Title(in Japanese)</b>	院内感染対策における耐性菌サーベイランスの活用
3.	<b>Main researcher</b>	Hiroshi Ohara (Bureau of International Health Cooperation, National Center for Global Health and Medicine)
4.	<b>Co-Researcher(s)</b>	Pokhrel BM, Shrestha RK, Dahal RK, Mishra SK, Kattel HP, Rijal BP (Dept. of Microbiology, Institute of Medicine, Tribhuvan University, Nepal) Jeevan B. Sherchand (Dept. of Public Health, Institute of Medicine, Tribhuvan University, Nepal) Jatan B. Sherchan (Dept. of Clinical Microbiology, Kathmandu University, School of Medicine, Nepal)
5.	<b>Resource of fund</b>	Grants of National Center for Global Health and Medicine (25-7, 27-4)
6.	<b>Affiliation(s) in Nepal</b>	Department of Microbiology, Institute of Medicine, Tribhuvan University, Dept. of Medical Microbiology, Kathmandu University, School of Medicine
7.	<b>Period of the research</b>	September 2014- March 2017
8.	<b>Publications in FY 2016 - 2017</b>	Sherchan JB, Gurung P, Karkee P, Ranabhat N, Shrestha N, Ohara H. Microbiological and clinical profile of uropathogenic <i>Escherichia coli</i> isolates in Kathmandu University Hospital. J Nepal Health Res Counc 2016; 14(32): 33-38.  Ohara H, Sherchan JB, Pokhrel BM, Sherchand JB. Review of collaboration between Tribhuvan University Institute of Medicine in Nepal and National Center for Global Health and Medicine in Japan on Nosocomial infection control and proposal for improvement. J Inst Med 2017; 39(2): 101-108.

## Research No.2

1.	<b>Title(in English)</b>	Molecular and Clinical Epidemiology of Salmonella Paratyphi A Isolated from Patients with Bacteremia in Nepal
2.	<b>Title(in Japanese)</b>	ネパールにおけるパラチフス菌血症患者の分子微生物学および臨床疫学的検討
3.	<b>Main researcher</b>	Kayoko Hayakawa (Disease Control and Prevention Center, National Center for Global Health and Medicine) Jatan Bahadur Sherchan (Department of Clinical Microbiology, Kathmandu University School of Medical Sciences, Dhulikhel, Nepal)
4.	<b>Co-Researcher(s)</b>	Masatomo Morita, Takashi Matono, Hidemasa Izumiya, Makoto Ohnishi(Department of Bacteriology I, National Institute of Infectious Diseases, Tokyo, Japan), Jeevan B. Sherchand, Sarmila Tandukar, Ujjwal Laghu (Public Health Research Laboratory, Institute of Medicine, Tribhuvan University Teaching Hospital, Kathmandu, Nepal), Maki Nagamatsu, Yasuyuki Kato, Norio Ohmagari (Disease Control and Prevention Center, National Center for Global Health and Medicine, Tokyo, Japan)
5.	<b>Resource of fund</b>	Clinical Epidemiology Research, St. Luke's International University, Tokyo, Japan (2016).
6.	<b>Affiliation(s) in Nepal</b>	Department of Medical Microbiology, Kathmandu University, School of Medical Sciences
7.	<b>Period of the research</b>	December 2014-March, 2017
8.	<b>Publications in FY 2016 - 2017</b>	Miyoshi-Akiyama T, Sherchan JB, Doi Y, Nagamatsu M, Sherchand JB, Tandukar S, Ohmagari N, Kirikae T, Ohara H, Hayakawa K. Comparative gene analysis of extended $\beta$ -spectrum $\beta$ -lactamase producing <i>Escherichia coli</i> sequence type 131 Strains from Nepal and Japan. Therapeutics Prevention 2016 e00289-16; 1(5): 1-13.  Sherchan JB, Morita M, Matono T, Izumiya H, Ohnishi M, Sherchand JB, Tandukar S, Laghu U, Nagamatsu M, Kato Y, Ohmagari N, Hayakawa K. Molecular and clinical epidemiology of <i>Salmonella paratyphi</i> A isolated from patients with bacteremia in Nepal. Am J Trop Med Hyg 2017; 97(6): 1706-1709.



### Research No.3

1.	Title(in English)	Molecular epidemiology of multidrug-resistant pathogens and development of diagnosis systems in Nepal
2.	Title(in Japanese)	ネパールの医療施設で分離される多剤耐菌の分子疫学解析および診断法の開発
3.	Main researcher	Tatsuya Tada (Department of Infectious Diseases, Research Institute, National Center for Global Health and Medicine) Shinichiro Morioka (Disease Control and Prevention Center, National Center for Global Health and Medicine)
4.	Co-Researcher(s)	Jeevan B. Sherchand (Dept. of Medical Microbiology, Tribhuvan University Teaching Hospital, Nepal)
5.	Resource of fund	Grants of National Center for Global Health and Medicine (29-5)
6.	Affiliation(s) in Nepal	Department of Microbiology, Institute of Medicine, Tribhuban University
7.	Period of the research	April 2016- March 2017
8.	Publications in FY 2016 - 2017	<p>Shrestha S, Tada T, Shrestha B, Kirikae T, Ohara H, Rijal BP, Pokhrel BM, Sherchand JB. Emergence of aminoglycoside resistance due to armA methylase in multi-drug resistant <i>Acinetobacter baumannii</i> isolates in a University Hospital in Nepal. J Nepal Health Res Counc 2016; 14(33): 72-76.</p> <p>Tada T, Shrestha S, Shimada K, Ohara H, Sherchand JB, Pokhrel BM, Kirikae T. PER-8 a novel extended-spectrum <math>\beta</math>-lactamase PER variant, from an <i>Acinetobacter baumannii</i> clinical isolate in Nepal. Antimicrob Agents Chemother 2017; 61(3) e00694-17: 1-5.</p> <p>Tada T, Shimada K, Satou K, Hirano T, Pokhrel BM, Sherchand JB, Kirikae T. <i>Pseudomonas aeruginosa</i> clinical isolates in Nepal coproducing metallo-<math>\beta</math>-lactamase and 16S rRNA methyltransferases. Antimicrob Agents Chemother 2017; 61(9) e00694-17: 1-6.</p> <p>Shrestha B, Tada T, Shimada K, Shrestha S, Ohara H, Pokhrel BM, Sherchand B, Kirikae T. Emergence of Various NDM-type-metallo-<math>\beta</math>-lactamase-producing <i>Escherichia coli</i> clinical isolates in Nepal. Antimicrob Agents Chemother 2017; 61(12) e01425-17: 1-6.</p>

**Research No.4**

1.	Title(in English)	Study on double burden tuberculosis (TB) and non-communicable diseases (NCD) in Nepal
2.	Title(in Japanese)	ネパールにおける結核と非感染性疾患の二重負荷に関する研究
3.	Main researcher	Takanori Hirayama, Shinsaku Sakurada (Bureau of International Health Cooperation, NCGM)
4.	Co-Researcher(s)	Yuko Tsuda (Health Bureau of Osaka City), Kiyohiko Izaumi (JATA/RIT), Shyam K Shrestha (FSB Clinic, Kathmandu), Jatan B Sherchan (Kathmandu University School of Medicine, Dhulikhel), Kishor S Manandhar (CF Clinic, Kathmandu), Jeevan B Sherchand (Tribhuvan University, Kathmandu)
5.	Resource of fund	Grants of National Center for Global Health and Medicine (24-5, 27-4)
6.	Affiliation(s) in Nepal	Department of Public Health, Institute of Medicine, Tribhuvan University, Kathmandu, Nepal
7.	Period of the research	September, 2012-March, 2018
8.	Publications in FY 2016 - 2017	None

## Research No.5

1.	Title(in English)	The survey of the present status of viral hepatitis treatment in Nepal
2.	Title(in Japanese)	ネパールにおけるウイルス肝炎治療に関する実態調査
3.	Main researcher	Naohiko Masaki, MD, PhD (Medical Director, Laboratory Testing Department, National Center for Global Health and Medicine)
4.	Co-Researcher(s)	Prof. Pradeep K. Shrestha (Department. of Internal Medicine, Teaching Hospital, Tribhuvan University), Prof. Yasuhito Tanaka (Departments of Virology & Liver Unit, Nagoya City University Graduate School of Medical Sciences), Prof. Hiroshi Ichimura (Department of Viral infection and International Health, Graduate School of Medical Sciences, Kanazawa University)
5.	Resource of fund	Grant-in-Aid for Scientific Research (B) (Overseas Academic Research) from Japan Society for the Promotion of Science to NM
6.	Affiliation(s) in Nepal	Department of Internal Medicine, Teaching Hospital, Tribhuvan University
7.	Period of the research	April 2015 - March 2018
8.	Publications in FY 2016 - 2017	<p>None in 2016, 2017 (Abstract of the following paper published in 2015 was put in this annual report 2016- 2017 for reference)</p> <p>Masaki N, Shrestha PK, Nishimura S, Ito K, Sugiyama M, Mizokami M. Use of nucleoside analogs in patients with chronic hepatitis B in Nepal: a prospective cohort study in a single hospital. <i>Hepatology Research</i> 2015; 45: 1163-1169.</p>

## List of papers published on international journals from 2012 to 2015:

### Achievement in NCGM-IOM Collaboration Office

Scientific papers which were published on international journals as results of collaborative studies during the period from 2012 to 2015 are shown below.

○ Full papers are put in this annual report 2016-2017 (Cf. Attachment)

○ Full papers are put in the annual report 2014 or 2015

These reports are available at: <http://www.ncgm.go.jp/kyokuhp/library/annual/index.html>

△ Abstract is put in the annual report 2016-2017

	Papers	
1	Sherchan JB, Ohara H, Sakurada S, Basnet A, Tandukar S, Sherchand JB, Bam DS. Enteric opportunistic parasitic infections among HIV-seropositive patients in Kathmandu, Nepal. Kathmandu Univ Med J 2012; 38(2):14-17.	○
2	Sherchan JB, Ohara H, Sherchand JB, Tandukar S, Sakurada S, Gurung B, Ansari S, Rijal BP, Pokhrel BM. Molecular evidence based hospital acquired rotavirus gastroenteritis in Nepal. Prime J Microbiol Res 2011; 1(2): 16-21.	○
3	Shrestha S, Chaudhari R, Karmacharya S, Kattel HP, Mishra SK, Dahal RK, Bam N, Banjade N, Rijal BP, Sherchand JB, Ohara H, Koirala J, Pokhrel BM. Prevalence of nosocomial lower respiratory tract infections caused by multi drug resistant pathogens. J Inst Med 2012; 33(2): 7-14.	○
4	Tada T, Miyoshi-Akiyama T, Dahal RK, Sah MK, Ohara H, Shimada K, Kirikae T, Pokhrel BM. NDM-8 metallo- $\beta$ -lactamase in a multidrug-resistant <i>Escherichia coli</i> strain isolated in Nepal. Antimicrob Agents Chemother 2013; 57(5): 2394-2396.	○
5	Shrestha RK, Dahal RK, Mishra SK, Parajuli K, Rijal BP, Sherchand JB, Kirikae T, Ohara H, Pokhrel BM. Ventilator associated pneumonia in tertiary care hospital, Maharajgunj, Kathmandu, Nepal. J Inst Med 2013; 35(3): 21-28.	○
6	Ohara H, Pokhrel BM, Dahal RK, Mishra SK, Kattel HP, Shrestha DL, Haneishi Y, Sherchand JB. Fact-finding survey of nosocomial infection control in hospitals in Kathmandu, Nepal and trial to improvement. Tropical Med Health 2013; 41:113-119.	○
7	Tada T, Miyoshi-Akiyama T, Dahal RK, Sah MK, Ohara H, Shimada K, Kirikae T, Pokhrel BM. NDM-1 metallo- $\beta$ -lactamase and ArmA 16S rRNA methylase producing <i>Providencia rettgeri</i> clinical isolates in Nepal. BMC Infect Dis 2014; 14:56-60	○
8	Tada T, Miyoshi-Akiyama T, Dahal RK, Mishra SK, Ohara H, Shimada K, Kirikae T, Pokhrel BM. Dissemination of multidrug-resistant <i>Klebsiella pneumoniae</i> clinical isolates with various combinations of carbapenemases (NDM-1 and OXA-72) and 16S rRNA methylases (ArmA, RmtC and RmtF) in Nepal. Int J Antimicrob Agents 2014; 42(4):372-374.	○

Papers		
9	Tada T, Shrestha B, Miyoshi-Akiyama T, Shimada K, Ohara H, Kirikae T, Pokhrel BM. NDN-12, a Novel New Delhi Metallo- $\beta$ -Lactamase Variant from a Carbapenem-Resistant <i>Escherichia coli</i> Clinical Isolate in Nepal. <i>Antimicrob Agents Chemother</i> 2014; 58(10):6302-6305.	○
10	Tada T, Miyoshi-Akiyama T, Dahal RK, Shyam MK, Shimada K, Ohara H, Kirikae T, Pokhrel BM. Identification of a Novel 6'-N-Aminoglycoside Acetyltransferase, AAC(6')-Iak from a Multidrug-resistant Clinical Isolates of <i>Stenotrophomonas maltophilia</i> . <i>Antimicrob Agents Chemother</i> 2014; 58(10):6324-6327.	○
11	Sha MK, Mishra SK, Ohara H, Kirikae T, Sherchand JB, Rijal BP, Pokhrel BM. Nosocomial bacterial infection and Antimicrobial resistant Pattern in a tertiary Care hospital in Nepal. <i>J Inst Med</i> 2014; 36(3): 38-48.	○
12	Sherchan JB, Hayakawa K, Miyoshi-Akiyama T, Ohmagari N, Kirikae T, Nagamatsu M, Tojo M, Ohara H, Sherchand JB, Tandukar S. Clinical epidemiology and molecular analysis of extended-spectrum $\beta$ -lactamase (ESBL)-producing <i>Escherichia coli</i> in Nepal: Characteristics of sequence types 131 and 648. <i>Antimicrob Agents Chemother</i> 2015; 59(6): 3424-3432.	○
13	Ohara H, Sherchand JB, Pokhrel BM, Hirayama T, Nam VH, Sherchan JB. Assessment of health systems in relation to interface between malaria control programs and health system strengthening: Comparative study between Nepal and Viet Nam. <i>J Inst Med</i> 2015; 37(1): 11-20.	○
14	Shrestha B, Tada T, Miyoshi-Akiyama T, Shimada K, Ohara H, Kirikae T, Pokhrel BM. Identification of a novel NDM variant, NDM-13, from a multidrug-resistant <i>Escherichia coli</i> clinical isolate in Nepal. <i>Antimicrob Agents Chemother</i> 2015; 59(9): 5847-5850.	○
15	Tada T, Miyoshi-Akiyama T, Shimada K, Dahal RK, Mishra SK, Ohara H, Kirikae T, Pokhrel BM. A novel 6'-N aminoglycoside acetyltransferase, AA(6')-Iai, from a clinical isolate of <i>Serratia marcescens</i> . <i>Microbial Drug Resist</i> 2015.	○
16	Masaki N, Shrestha PK, Nishimura S, Ito K, Sugiyama M, Mizokami M. Use of nucleoside analogs in patients with chronic hepatitis B in Nepal: a prospective cohort study in a single hospital. <i>Hepatology Research</i> 2015; 45: 1163-1169.	○ △ P21
17	Sherchand JB. Earthquake disaster-associated health effects and the need for improved preventive measures. <i>J Inst Med</i> 2015; 37(1): 1-3.	○
18	Sherchan JB, Gurung P, Karkee P, Ranabhat N, Shrestha N, Ohara H. Microbiological and clinical profile of uropathogenic <i>Escherichia coli</i> isolates in Kathmandu University Hospital. <i>J Nepal Health Res Counc</i> 2016; 14(32): 33-38.	◎ P22
19	Shrestha S, Tada T, Shrestha B, Kirikae T, Ohara H, Rijal BP, Pokhrel BM, Sherchand JB. Emergence of aminoglycoside resistance due to armA methylase in multi-drug resistant <i>Acinetobacter baumannii</i> isolates in a University Hospital in Nepal. <i>J Nepal Health Res Counc</i> 2016; 14(33): 72-76.	◎ P28

Papers		
20	Miyoshi-Akiyama T, Sherchan JB, Doi Y, Nagamatsu M, Sherchand JB, Tandukar S, Ohmagari N, Kirikae T, Ohara H, Hayakawa K. Comparative gene analysis of extended-spectrum $\beta$ -lactamase producing <i>Escherichia coli</i> sequence type 131 Strains from Nepal and Japan. <i>Therapeutics Prevention</i> 2016 e00289-16; 1(5): 1-13.	◎ P33
21	Tada T, Shrestha S, Shimada K, Ohara H, Sherchand JB, Pokhrel BM, Kirikae T. PER-8 a novel extended-spectrum $\beta$ -lactamase PER variant, from an <i>Acinetobacter baumannii</i> clinical isolate in Nepal. <i>Antimicrob Agents Chemother</i> 2017; 61(3) e00694-17: 1-5.	◎ P47
22	Sherchan JB, Morita M, Matono T, Izumiya H, Ohnishi M, Sherchand JB, Tandukar S, Laghu U, Nagamatsu M, Kato Y, Ohmagari N, Hayakawa K. Molecular and clinical epidemiology of <i>Salmonella paratyphi</i> A isolated from patients with bacteremia in Nepal. <i>Am J Trop Med Hyg</i> 2017; 97(6): 1706-1709.	◎ P52
23	Ohara H, Sherchan JB, Pokhrel BM, Sherchand JB. Review of collaboration between Tribhuvan University Institute of Medicine in Nepal and National Center for Global Health and Medicine in Japan on Nosocomial infection control and proposal for improvement. <i>J Inst Med</i> 2017; 39(2): 101-108.	◎ P56
24	Tada T, Shimada K, Satou K, Hirano T, Pokhrel BM, Sherchand JB, Kirikae T. <i>Pseudomonas aeruginosa</i> clinical isolates in Nepal coproducing metallo- $\beta$ -lactamase and 16S rRNA methyltransferases. <i>Antimicrob Agents Chemother</i> 2017; 61(9) e00694-17: 1-6.	◎ P64
25	Shrestha B, Tada T, Shimada K, Shrestha S, Ohara H, Pokhrel BM, Sherchand B, Kirikae T. Emergence of Various NDM-type-metallo- $\beta$ -lactamase-producing <i>Escherichia coli</i> clinical isolates in Nepal. <i>Antimicrob Agents Chemother</i> 2017; 61(12) e01425-17: 1-6	◎ P70



Academic building of Tribhuvan University Institute of Medicine (IOM, Left) and Teaching Hospital (TUTH, Right)

**Original Article**

## Use of nucleoside analogs in patients with chronic hepatitis B in Nepal: A prospective cohort study in a single hospital

Naohiko Masaki,<sup>1\*</sup> Pradeep Krishna Shrestha,<sup>3</sup> So Nishimura,<sup>2\*</sup> Kiyooki Ito,<sup>1\*</sup> Masaya Sugiyama<sup>1</sup> and Masashi Mizokami<sup>1</sup>

<sup>1</sup>The Research Center for Hepatitis and Immunology, <sup>2</sup>Kohnodai Hospital, National Center for Global Health and Medicine, Chiba, Japan, and <sup>3</sup>Department of Medicine, Tribhuvan University, Kathmandu, Nepal

**Aim:** There still remain many concerns about the present status of antiviral therapy for chronic hepatitis B in developing countries in Asia, where the monitoring systems of virological markers have not been well established, despite the high prevalence of hepatitis B virus (HBV) infection. To investigate it in Nepal, this prospective cohort study was conducted at the Teaching Hospital of Tribhuvan University in Kathmandu.

**Methods:** From 2007 to 2012, 65 patients were consecutively enrolled, 44 of whom received nucleoside analogs (NA), such as lamivudine (LMV), adefovir or tenofovir (TDF), on the decision of the local hepatologist. Virological determinations were performed in Japan, by using the serially collected serum samples at the Teaching Hospital. Statistical analysis was performed, using Mann–Whitney *U*-test or Fisher's exact test.

**Results:** The younger, especially female patients of reproductive age were more frequently prescribed with these NA, and an increased preference for the use of TDF was observed over time. However, there was insufficient follow up of the NA-treated patients in this cohort, and not a few patients developed emergence of NA-resistant HBV: known resistance to LMV in 3 patients and incidental resistance to non-administrated NA in four patients.

**Conclusion:** The results of the present study indicate that education for physicians as well as for infected patients regarding the proper use of NA, together with establishment of appropriate monitoring systems for virological markers, is warranted to prevent an increase in NA-resistant HBV infections in Nepal.

**Key words:** antiviral therapy, chronic hepatitis B, hepatitis B virus, nucleoside analogs, resistance

**INTRODUCTION**

ACCORDING TO ESTIMATES by the World Health Organization, almost 240 million people are infected by hepatitis B virus (HBV) worldwide, and up to 780 000

deaths related to liver cirrhosis or hepatocellular carcinoma caused by chronic HBV infection occur annually.<sup>1</sup> HBV infection is endemic, particularly in Asian and African countries, and the prevalence is reported to be as high as 20% of the general population in some countries.<sup>2</sup> In the rural areas of Nepal, one of the poorest countries in the world, the prevalence of HBV and hepatitis C virus (HCV) among blood donors was reported to be 0.86% and 0.52%, respectively, in 2001–2002.<sup>3</sup> Our epidemiological study conducted between 1997 and 2002 also demonstrated that HBV and HCV carrier rates among 540 blood donors in the urban area of Nepal were 2.4% and 1.1%, respectively (e.g. N. Masaki, unpubl. data, 2003).

The recent introduction of nucleoside analogs (NA) such as lamivudine (LMV), adefovir (ADF), entecavir (ETV) and tenofovir (TDF) into clinical settings has significantly attenuated the progression of liver fibrosis and hepatocarcinogenesis,<sup>4</sup> leading to improvements in the

Correspondence: Dr Naohiko Masaki, The Research Center for Hepatitis and Immunology, National Center for Global Health and Medicine, Kohnodai 1-7-1 Ichikawa, Chiba 272-8516, Japan. Email: nmasaki0808@gmail.com

\*Author contribution: N. M. designed the research protocol, obtained funding and wrote the first draft of the manuscript. P. K. S. was the counterpart of this research in Nepal and contributed to the collection of serum samples as well as clinical information. S. N. and K. I. contributed to the acquisition of data and the analysis. M. S. carried out the molecular analyses of hepatitis B virus. M. M. supervised the entire research project. All authors read and approved the final manuscript.

†Present addresses: S. N. and K. I. are now affiliated with Saiseikai Fukuoka General Hospital, Fukuoka, Japan, and Department of Gastroenterology, Aichi Medical University School of Medicine, Aichi, Japan, respectively. Received 14 August 2014; revision 23 December 2014; accepted 5 January 2015.

© 2015 The Authors.

Hepatology Research published by Wiley Publishing Asia Pty Ltd on behalf of The Japan Society of Hepatology  
This is an open access article under the terms of the Creative Commons Attribution-NonCommercial-NoDerivs License, which permits use and distribution in any medium, provided the original work is properly cited, the use is non-commercial and no modifications or adaptations are made.

1163

## Microbiological and Clinical Profile of Uropathogenic *Escherichia coli* Isolates in Kathmandu University Hospital

Sherchan JB,<sup>1</sup> Gurung P,<sup>2</sup> Karkee P,<sup>1</sup> Ranabhat N,<sup>1</sup> Shrestha N,<sup>1</sup> Ohara H<sup>3</sup>

<sup>1</sup>Department of Microbiology, Kathmandu University School of Medical Sciences, Dhulikhel, <sup>2</sup>Kathmandu Medical College, Kathmandu, Nepal, <sup>3</sup>National Center for Global Health and Medicine, Japan.

### ABSTRACT

**Background:** Treatment of patients infected by multidrug resistant bacteria is a major challenge. Immunocompromised status, prolonged hospital stay, malignancy, diabetes are some of the risk factors for emergence of multidrug resistance. Our study focused on microbiological and clinical profile of multidrug resistant uropathogenic *Escherichia coli*.

**Methods:** This was a cross-sectional study conducted between June 2014-May 2015 in Kathmandu University Hospital. Urine sample from outpatients and inpatients from which *Escherichia coli* isolated was included. Specimen collection, culture, identification tests were done following guidelines given by American Society for Microbiology.

**Results:** Total number of urine samples received during the study were 3,554. *Escherichia coli* isolates were 645(18.14%) and 245(37.98%) were Extended Spectrum Beta-Lactamase producer. Extended Spectrum Beta-Lactamase producers were found more among inpatients 148(60.41%) [p<0.001], patients with underlying urological abnormalities 38 (15.51%) [p=0.0039], pregnant ladies 46(18.77%) [p=0.0028], diabetic patients 27 (11.02%) [p=0.0084], patients who received prior antibiotic therapy 155 (63.26%) [p=0.0043] than Extended Spectrum Beta-Lactamase non-producer. Malignancy was seen more among Extended Spectrum Beta-Lactamase producer having patients 5 (2.04%) [p=0.031] and all these isolates were more resistant to fluoroquinolones 168(68.57%), Trimethoprim-sulfamethoxazole 239 (97.55%) [p=0.0633], aminoglycosides [p=0.0001] but only 2(0.80%) were resistant to carbapenems.

**Conclusions:** Diabetes, pregnancy, malignancy, prior antibiotic therapy, underlying urological abnormalities were found associated with emergence of Extended Spectrum Beta-Lactamase producer in urine samples. Proper antibiotic usage may help to overcome the problem of emergence of antibiotic resistance.

**Keywords:** Extended Spectrum Beta-Lactamase, *Escherichia coli*, multidrug resistant.

### INTRODUCTION

Antimicrobials remain the mainstay of empirical therapy; however, indiscriminate use of antibiotics in many developing countries including Nepal has resulted in the outbreak of drug resistant microorganisms.<sup>1</sup> It has been found and mentioned that, the importance of Extended Spectrum Beta-Lactamase producer (ESBL)-mediated infections has been increasing.<sup>2-4</sup> ESBL-producing infections have been found associated with both negative clinical outcomes and increased cost.<sup>5,6</sup>

Failure to adhere to proper infection control technique,

unrationale use of antibiotics, unhygienic practices, increased uses of antibiotics in animal and plants and more so availability of antibiotics without prescription and counterfeit products of dubious quality in developing countries have resulted in spread of antimicrobial resistance and selection of multidrug resistant bacterial pathogens.<sup>1,7,8</sup> Unless we gather the information about the existing multidrug resistant (MDR) strains, the rate of emergence and spread of antimicrobial resistance cannot be reduced.<sup>9</sup>

With resistance to each additional class of antibiotics, ESBL-EK (*Escherichia*, *Klebsiella*) infections become a

Correspondence: Jatan B. Sherchan, Department of Microbiology, Kathmandu University School of Medical Sciences, Dhulikhel, Nepal. Email: jatansherchan@gmail.com.



Microbiological and Clinical Profile of Uropathogenic *Escherichia Coli* Isolates

greater therapeutic challenge. Reliance on carbapenems has increased; because they are the only class of agents to which ESBL-EK remain almost uniformly susceptible. However, empirical treatment of suspected ESBL-EK infections with carbapenems has been associated with significant increases in carbapenem resistance in other organisms (e.g., *Pseudomonas aeruginosa* and *Acinetobacter calcoaceticus*).<sup>10-12</sup>

In 1983, the first outbreak involving extended spectrum beta-lactamase (ESBL) producing organisms was reported in Germany.<sup>13</sup> These ESBL-producing pathogens are now recognized globally as major causes of nosocomial and community-acquired infections.<sup>14</sup>

Several cases of multidrug resistant bacterial outbreaks of significant clinical concern have been frequently reported.<sup>15-17</sup>

Risk factors for colonization or infection with multidrug-resistant bacterial species include prolonged length of hospital stay, exposure to an ICU, receipt of mechanical ventilation, colonization pressure, and exposure to broad-spectrum antimicrobial agents, recent surgery, invasive procedures, and underlying severity of illness.<sup>18,19</sup> Patients who are infected with multidrug resistant bacteria have to stay in the hospital or have to be treated longer. Treating such patient has become a big challenge to the clinicians and patients for economic burden. Research on such situation may become a useful tool to overcome such situation in future. This study might be one of a good source to identify the burden of multidrug resistance pathogen, which might help to prepare guidelines for infection control and antibiotic policy.

## METHODS

This was a cross-sectional study carried out at Kathmandu University Hospital, Dhulikhel, Nepal. Urine sample from outpatients and inpatients collected between June 2014 to May 2015 from which *Escherichia coli* was isolated (with special reference to ESBL) was included in the study. Clinical and epidemiological information was collected from the patient after taking informed consent from the patient.

Ethical clearance was taken from Institutional Review Committee of Kathmandu University Hospital before the study was conducted.

Specimen collection, culture, identification tests were done according to the guidelines given by American Society for Microbiology.<sup>20</sup> The antibiotic susceptibility

test of the pathogens isolated from the clinical specimen against different antibiotics was done using Mueller Hinton agar (MHA) (Oxoid, United Kingdom) by the standard disk diffusion technique of modified Kirby-Bauer method as recommended by Clinical and Laboratory Standards Institute (CLSI).<sup>21</sup>

Definition of ESBL: They are capable of hydrolyzing penicillins, broad-spectrum cephalosporins and monobactams, but they do not affect the cephamycins or carbapenems and their activity is inhibited by clavulanic acid.<sup>22</sup>

The initial screen test for the production of ESBL was performed by using ceftriaxone (CRO) (30 µg), ceftazidime (CAZ) (30 µg) and cefotaxime (CTX) (30 µg) disks (Oxoid, UK). If the zone of inhibition (ZOI) was ≤ 25 mm for CRO, ≤ 22 mm for CAZ and/or ≤ 27 mm for CTX, the isolate was considered a potential ESBL-producer as recommended by CLSI.<sup>21</sup>

Combination disk (CD) method was used for the phenotypic confirmation of ESBL-producing strains in which CTX and CAZ (30 µg), alone and in combination with clavulanic acid (CA) (10 µg) was used (Becton Dickinson, USA). An increased ZOI of ≥ 5 mm for either antimicrobial agent tested in combination with CA versus its zone when tested alone confirmed ESBL.<sup>21</sup>

Data were analyzed by (SPSS) version 11.5 software and P value less than 0.05 was considered to be significant.

## RESULTS

Total number of urine sample received during the study period was 3,554 out of which significant bacterial growth was observed in 835 (23.49%) samples and out of this total number *Escherichia coli* isolates was 645 (18.14%). Of total 645 *E. coli* 245(37.98%) were ESBL producer and 400(62.01%) were non-ESBL producer. Of total 245 ESBL *E. coli* 148 (60.41%) isolates were found among inpatients and 97 (39.59%) were found among outpatients. Of total 400 non-ESBL *E. coli* 142 (35.50%) isolates were found among inpatients and 258 (64.50%) were found among outpatients. ESBL *E. coli* isolates were found more among inpatients (60.41%) compared to Non-ESBL *E. coli* (35.5%), which was statistically significant. ( $p < 0.001$ )

38 (15.51%) patients from whom ESBL *E. coli* was isolated had underlying urological abnormalities whereas only 32 (8.00%) of patients from whom non-ESBL *E. coli* was isolated had underlying urological abnormalities. ( $p = 0.0039$ )

## Microbiological and Clinical Profile of Uropathogenic Escherichia Coli Isolates

46 (18.77%) patients from whom ESBL *E. coli* was isolated were pregnant whereas only 41 (10.25%) patients from whom non-ESBL *E. coli* was isolated were pregnant. (p value=0.0028)

91 (37.14%) patients from whom ESBL *E. coli* was isolated had complicated UTI whereas only 55 (13.75%) patients from whom non-ESBL *E. coli* was isolated had complicated UTI. (p<0.001)

27 (11.02%) patients from whom ESBL *E. coli* was

isolated were diabetic whereas only 21 (5.25%) patients from whom non-ESBL *E. coli* was isolated were diabetic. (p=0.0084)

5 (2.04%) patients from whom ESBL *E. coli* was isolated had malignancy whereas only 1 (0.25%) patients from whom non-ESBL *E. coli* was isolated had malignancy. (p value = 0.031)

155 (63.26%) patients from whom ESBL *E. coli* was isolated received prior antibiotic therapy whereas only

**Table 1. Clinico-epidemiological characteristics of ESBL vs. non-ESBL *Escherichia coli* from urine samples**

	ESBL isolates (n = 245, 38 %)	Non-ESBL isolates (n = 400, 62 %)	ESBL vs. Non-ESBL P value
Male patients	74 (30.20%)	124 (31.00%)	0.86
Female patients	171 (69.79%)	276 (69.00%)	
Outpatients	97 (39.59%)	258 (64.50%)	0.0001
Patients with underlying urological condition	38 (15.51%)	32 (8.00%)	0.0039
Pregnant patients	46 (18.77%)	41 (10.25%)	0.0028
Complicated UTI	91 (37.14%)	55 (13.75%)	0.0001
Uncomplicated UTI	154 (62.85%)	345 (86.25%)	
Patients with DM	27 (11.02%)	21 (5.25%)	0.0084
Patients with cancer	5 (2.04%)	1 (0.25%)	0.031
Prior antibiotic therapy	155 (63.26%)	207 (51.75%)	0.0043

**Table 2. Susceptibility profile of ESBL- *E. coli* and non-ESBL *E. coli* for various antibiotics.**

Antimicrobial agents	ESBL- <i>E. coli</i> resistant (n=245)	Non-ESBL- <i>E. coli</i> resistant (n=400)	p-value
Ampicillin/Amoxicillin (10µg)	245 (100%)	267 (66.75%)	
Cefuroxime (30µg)	245 (100%)	233 (58.25%)	
Norfloxacin (10µg)	168 (68.57%)	245 (61.25%)	0.0633
Trimethoprim-sulfamethoxazole (1.25/23.75 µg)	239 (97.55%)	373 (93.25%)	0.0163
Gentamicin (10µg)	166 (67.75%)	102 (25.50%)	0.0001
Amikacin (30µg)	25 (10.20%)	5 (1.25%)	0.0001
Amoxicillin-clavulanic acid (20/10µg)	245 (100%)	15 (3.75%)	
Cefotaxime (30µg)	245 (100%)	12 (3.00%)	
Netilmicin (30µg)	148 (60.40%)	17 (4.25%)	0.0001
Aztreonam (30µg)	245 (100%)	7 (1.75%)	
Cefepime/Cefpirome (30µg)	211 (86.12%)	4 (1.00%)	
Cefoperazone-salbactam (75/30µg)	245 (100%)	2 (0.50%)	
Piperacillin-tazobactam (100/10µg)	245 (100%)	6 (1.5%)	
Ticarcillin-clavulanic acid (75/10µg)	245 (100%)	8 (2.00%)	
Imipenem (10µg)	2 (0.80%)	0 (0.00%)	
Meropenem (10µg)	2 (0.80%)	0 (0.00%)	

Includes intermediate and resistant isolates, based on CLSI criteria, 2013

207 (51.75%) from whom non-ESBL *E. coli* was isolated received prior antibiotic therapy. (p value=0.0043).

Fluoroquinolone resistance was observed more among ESBL *E. coli* 168 (68.57%) than non-ESBL *E. coli* 245 (61.25%). [p=0.0633]

Trimethoprim-sulfamethoxazole resistance was observed more among ESBL *E. coli* 239 (97.55%) than non-ESBL *E. coli* 373 (93.25%). [p=0.0163]

Aminoglycoside resistance was also observed more among ESBL *E. coli* [p<0.001]

Of total 245 ESBL *E. coli* only 2 (0.80%) were resistant to Carbapenems.

## DISCUSSION

Certain strains of *Escherichia coli* can cause a wide variety of intestinal and extra-intestinal diseases such as urinary tract infection, diarrhea, septicemia and neonatal meningitis.<sup>23</sup> Nosocomial infections caused by Extended Spectrum Beta-Lactamase producing pathogens are associated with risk factors such as elderly age, prolonged hospitalization, previous antibiotic use, and presence of invasive devices.<sup>14,24</sup> In our study duration total urine sample received was 3,554 out of which 835 had significant bacterial growth and out of this 645 (77.24%) were *Escherichia coli*. Among total 645 *E. coli*, which were screened for ESBL production, 245 (37.98%) were ESBL producer and 400 (62.02%) were non-ESBL producer. This finding was more than the finding done by Datta et.al in which out of total 140 strains of *E. coli*, which were screened for ESBL production, only 30 (21.4%) isolates were positive.<sup>25</sup> This may reflect that their antibiotic policy and antibiotic usage is better. ESBL *E. coli* isolates were found more among inpatients 148 (60.41%) compared to Non-ESBL *E. coli* 142 (35.50%), which was statistically significant (p<0.001). This means ESBL *E. coli* isolated were more encountered among hospital isolates indicating it might be nosocomial infection. This finding is similar to the finding observed by Husam. et.al in which ESBL producers among urinary *E. coli* isolates was significantly higher among in-patients.<sup>26</sup> Mean age of the patients with ESBL *E. coli* was 48.8 ± 22.3 and mean age of patients with non-ESBL *E. coli* was 40.8 ± 23.2. This means ESBL *E. coli* was detect more among patients of higher age group and old age remains one of the risk factor, which is similar to observation by Husam. et.al.<sup>26</sup> In our study of total 645 patients from whom *E. coli* was isolated 447 (69.30%) were female and 198 (30.70%) were male. It is true and it has been mention in many studies that females are more prone to urinary tract infection compared to the

males.<sup>27-29</sup> Of total 245 patients from whom ESBL *E. coli* was isolated 171 (69.79%) were female and 74 (30.21%) were male.

In the past few years, the number of complicated UTI due to resistant gram-negative bacteria has risen, mainly due to spread of extended spectrum β-lactamase (ESBL) bacteria, which pose a significant therapeutic challenge. Although a broad range of pathogens can cause complicated UTI, *Escherichia coli* remains the most common.<sup>30</sup>

Our study found similar observation as mentioned above in which 91 (37.14%) patients from whom ESBL *E. coli* was isolated had complicated UTI whereas only 55 (13.75%) patients from whom non-ESBL *E. coli* was isolated had complicated UTI (p<0.001) This means underlying urological abnormalities such as nephrolithiasis, benign prostatic hyperplasia, prostatic cancer, presence of invasive devices etc may be risk factor for acquiring urinary tract infection by ESBL *E. coli*.

In our study, 46 (18.77%) patients from whom ESBL *E. coli* was isolated were pregnant where as only 41 (10.25%) patients from whom non-ESBL *E. coli* was isolated were pregnant. (p value=0.0028) This means pregnancy might be risk factor for acquiring UTI by ESBL *E. coli*. In study conducted by Dutta et. al out of total 30 patients from whom ESBL *E. coli* isolates were detected, 11 (37%) were pregnant, which seems much more than our findings.<sup>25</sup> It may be because our maternity and birth center follows guidelines more strictly than their settings. In a study conducted by Aswani Srinivas et.al ESBL producing *E. coli* was significantly higher in diabetics (p value= 0.001) compared to non-diabetics.<sup>31</sup> In our study though we did not compare prevalence of ESBL *E. coli* among diabetics and non-diabetics we found higher number 27(11.02%) diabetic patients with ESBL *E. coli* in urine compared to less number 21(5.25%) diabetic patients with non-ESBL *E. coli*. (p value=0.0084) This result shows that diabetes may be another risk factor for acquiring multidrug resistant bacteria.

In our study 5 (2.04%) patients from whom ESBL *E. coli* was isolated had malignancy whereas only 1(0.25%) patients from whom non-ESBL *E. coli* was isolated has malignancy. (p value = 0.031) indicating underlying comorbid illness like malignancy might be a risk factor for acquiring ESBL *E. coli*.

In our study Fluoroquinolone resistance was observed more among ESBL *E. coli* 168 (68.57%) than non-ESBL *E. coli* 245 (61.25%). [p value=0.0633] which was quite

## Microbiological and Clinical Profile of Uropathogenic Escherichia Coli Isolates

similar to finding observed by Husam S. et. al in which high levels of ciprofloxacin resistance was found among ESBL isolates. <sup>26</sup> This means fluoroquinolones should be used cautiously if ESBL *E. coli* is suspected from urine sample. In our study Trimethoprim-sulfamethoxazole resistance was observed more among ESBL *E. coli* 239 (97.55%) than non-ESBL *E. coli* 373 (93.25%). [p=0.0163] and aminoglycoside resistance was also observed more among ESBL *E. coli* [p<0.001]

In our study 155 (63.26%) patients from whom ESBL *E. coli* was isolated received prior antibiotic therapy whereas only 207 (51.75%) from whom non-ESBL *E. coli* was isolated received prior antibiotic therapy. (p value=0.0043) This finding might suggest that prior antibiotic therapy might be a risk factor for acquiring ESBL *E. coli*.

This study do has some limitations. Since, it was carried out in a single center the results may not be applicable to settings with a different epidemiology. In addition, only urine sample was screened for ESBL *E. coli* not including other clinical sample like blood, pus, wound swab, sputum etc.

### CONCLUSIONS

Several factors were found associated with emergence of Extended Spectrum Beta-Lactamase producing *Escherichia coli* from urine sample. Extended Spectrum Beta-lactamase producing *Escherichia coli* was found more resistant to other group of drugs as well. But less than one percent of them were resistant to carbapenem. Hospital-acquired Extended Spectrum Beta-Lactamase producers are emerging challenge and proper antibiotic usage following antibiotic policy may help to some extent to over come this.

### ACKNOWLEDGMENTS

We express our profound gratitude to Kathmandu University Hospital and National Center for Global Health and Medicine, Tokyo, Japan for their valuable support in this study.

### REFERENCES

1. American Academy of Microbiology. Antibiotic Resistance: An Ecological Perspective of an Old Problem. ASM Press, Washington D.C; 2009.
2. Burwen DR, Banerjee SN, Gaynes RP. Ceftazidime resistance among selected nosocomial gram-negative bacilli in the United States. The National Nosocomial Infections Surveillance System. J Infect Dis 1994; 170:1622-5.
3. Itokazu GS, Quinn JP, Bell-Dixon C, Kahan FM, Weinstein RA. Antimicrobial resistance rates among aerobic gram-negative bacilli recovered from patients in intensive care units: evaluation of a national postmarketing surveillance program. Clin Infect Dis 1996; 23:779-84.
4. Nijssen S, Florijn A, Bonten MJM, Schmitz FJ, Verhoef J, Fluit AC. b- Lactam susceptibilities and prevalence of ESBL-producing isolates among more than 5000 European Enterobacteriaceae isolates. Int J Antimicrob Agents 2004; 24:585-91.
5. Lautenbach E, Patel JB, Bilker WB, Edelstein PH, Fishman NO. Extended-spectrum b-lactamase-producing *Escherichia coli* and *Klebsiella pneumoniae*: risk factors for infection and impact of resistance on outcomes. Clin Infect Dis 2001; 32:1162-71.
6. Paterson DL, Ko WC, Von Gottberg A, Mohapatra S, Casellas JM, Goossens H, et al. International prospective study of *Klebsiella pneumoniae* bacteremia: implications of extended- spectrum beta-lactamase production in nosocomial infections. Ann Intern Med 2004; 140:26-32.
7. Murray PR, Barron EJ, Jorgensen JH, Pfaller MA, Tenover FC, Tenover FC, editors. Manual of Clinical Microbiology 8<sup>th</sup> ed. ASM Press, Washington D.C: 2003.
8. Byarugaba DK. A view on antimicrobial resistance in developing countries and responsible risk factors. Int'l J Antimicrob Agents 2004; 24: 105-10.
9. Tuladhar, N.R., Banjade, N., Pokhrel, B.M. Comparative study of multi-drug resistant strains of respiratory pathogens among in and out patients of Tribhuvan University Teaching Hospital, Kathmandu, Nepal. Journal of Nepal Association for Medical Laboratory Sciences, 6. 19-24, 2004.
10. Rahal JJ, Urban C, Horn D, Freeman K, Segal-Maurer S, Maurer J et al. Class restriction of cephalosporin use to control total cephalosporin resistance in nosocomial *Klebsiella*. JAMA 1998;280:1233-7.
11. Urban C, Go E, Mariano N, Nerger BJ, Avraham I, Rubin D et al. Effect of sulbactam on infections caused by imipenem-resistant *Acinetobacter calcoaceticus* biotype anitratus. J Infect Dis 1993; 167:448-51.
12. Wong-Beringer A. Therapeutic challenges associated with extended- spectrum, b-lactamase-producing

## Microbiological and Clinical Profile of Uropathogenic Escherichia Coli Isolates

- Escherichia coli and Klebsiella pneumoniae. Pharmacotherapy 2001; 21:583-92.
13. Knothe H, Shah P, Krcmery V, Antal M, Mitsuhashi S. Transferable resistance to cefotaxime, ceftazidime, cefamandole and cefuroxime in clinical isolates of Klebsiella pneumoniae and Serratia marcescens. Infection 11: 315-317.
  14. Bradford PA. Extended-spectrum beta-lactamases in the 21st century: characterization, epidemiology, and detection of this important resistance threat. Clin Microbiol Rev. 2001;14: 933-951.
  15. Rai SK, Pokhrel BM, Tuladhar NR, Khadka JB, Upadhyaya MP. Methicillin resistant coagulase negative Staphylococci. J Inst Med (Nepal) 1987; 9: 23-8.
  16. Rai SK, Tuladhar NR, Shrestha HG. Methicillin resistant Staphylococcus aureus in a tertiary medical care center, Nepal. Indian J Med Microbiol 1990; 8:108-9.
  17. Pokharel BM, Koirala J, Dahal RK, Mishra SK, Khadka PK, Tuladhar NR. Multidrug-resistant and extended-spectrum beta-lactamase (ESBL)-producing Salmonella enterica (serotypes Typhi and Paratyphi A) from blood isolates in Nepal: surveillance of resistance and a search for newer alternative. Int'l J Infect Dis 2006; 6: 434-38.
  18. Fournier PE, Richet H. The epidemiology and control of Acinetobacter baumannii in health care facilities. Clin Infect Dis. 2006; 42(5): 692-9.
  19. Playford EG, Craig JC, Iredell JR. Carbapenem-resistant Acinetobacter baumannii in intensive care unit patients: risk factors for acquisition, infection and their consequences. J Hosp Infect. 2007;65(3):204-11.
  20. Isenberg, HD. Clinical Microbiology Procedures Handbook. 2<sup>nd</sup> Ed. Washington D.C., ASM press, 2004.
  21. Clinical and Laboratory Standards Institute. Performance standards for antimicrobial susceptibility testing, 17th informational supplement. Wayne, PA, M100-S17, 2007.
  22. Paterson DL, Bonomo RA. Extended-spectrum beta-lactamases: a clinical update. Clin Microbiol Rev. 2005;18: 657- 86.
  23. Orskov F, Orskov I. Escherichia coli serotyping and disease in man and animals. Can J Microbiol. 1992;38:699-704.
  24. Panhotra BR, Saxena AK, Al-Ghamdi AM. Extended-spectrum beta-lactamase-producing Klebsiella pneumoniae hospital acquired bacteremia. Risk factors and clinical outcome. Saudi Med J. 2004; 25: 1871-1876.
  25. Datta P, Gupta V, Sidhu S. Extended spectrum beta lactamase positive uropathogenic E. coli - Epidemiological Factors and Resistance. BJMP 2014;7(2):a718
  26. Husam S, Khanfar, Khalid M. Bindayna, Abiola C. Senok, and Giuseppe A. Botta Extended spectrum beta-lactamases (ESBL) in Escherichia coli and Klebsiella pneumoniae: trends in the hospital and community settings. J Infect Dev Ctries 2009; 3(4): 295-9.
  27. Komaroff AL. Urinalysis and urine culture in women with dysuria. Ann Intern Med. 1986;104:212-8.
  28. Stamm WE, Hooton TH. Management of urinary tract infections in adults. N Engl J Med. 1993;329:1328-34.
  29. Wong ES, Fennell CI, Stamm WE. Urinary tract infection among women attending a clinic for sexually transmitted diseases. Sex Transm Dis. 1984; 11:18-23.
  30. Nicolle LE. A practical guide to the management of complicated urinary tract infection. Drugs. 1997; 53:583-92.
  31. Aswani Srinivas M, Chandrashekar UK, Shivashankara KN, Pruthvi BC. Clinical profile of urinary tract infections in diabetics and non-diabetics. Australas Med J. 2014; 7 (1): 29-34.

J Nepal Health Res Counc 2016 May - Aug;14(33):72-6

## Emergence of Aminoglycoside Resistance Due to armA methylase in Multi-drug Resistant Acinetobacter Baumannii Isolates in a University Hospital in Nepal

Shrestha S,<sup>1</sup> Tada T,<sup>2</sup> Shrestha B,<sup>1</sup> Kirikae T,<sup>2</sup> Ohara H,<sup>2</sup> Rijal BP,<sup>1</sup> Pokhrel BM,<sup>1</sup> Sherchand JB<sup>1</sup>

<sup>1</sup>Department of Microbiology, Institute of Medicine, Tribhuvan University Teaching Hospital, Kathmandu, Nepal,

<sup>2</sup>National Center for Global Health and Medicine, Tokyo, Japan.

### ABSTRACT

**Background:** The emergence of multidrug-resistant *Acinetobacter baumannii* associated with hospital-acquired infections has been increasingly reported worldwide. 16S rRNA methylase producing Gram-negative bacteria are highly resistant to all clinically important aminoglycosides. We analyzed *A. baumannii* clinical isolates resistant to aminoglycosides from hospitalized patients. The objective of this study was to investigate the emergence of armA in *A. baumannii* species associated with nosocomial infection in a university hospital in Nepal.

**Methods:** This was a cross-sectional study conducted at the department of Clinical Microbiology, Tribhuvan University Teaching Hospital (TUTH), from December 2013 to December 2014. A total of 246 *Acinetobacter* species were isolated from different patients were screened for MDR *A. baumannii*. Identification at the species level was confirmed by 16S rRNA sequencing. Drug susceptibility testing was performed by Kirby-Bauer disc diffusion method and minimum inhibitory concentrations (MICs) were determined using the guidelines of the Clinical and Laboratory Standards Institute (CLSI). Screening for 16S rRNA methylase-production was done for the isolates resistant to gentamicin and amikacin. Detection of 16S rRNA methylase gene was done by PCR.

**Results:** All 122 multidrug-resistant *A. baumannii* isolates were resistant to majority of the antibiotics used except polymyxin and tigecycline. Ninety-six MDR *A. baumannii* isolates had MICs of > 512 mg/L to amikacin and arbekacin indicating their high resistance to aminoglycosides. Of the 96 pan-aminoglycoside resistant isolates, 75 isolates had 16SrNAMethylase with all isolates harboring armA gene.

**Conclusions:** This is the first report describing multidrug-resistant *A. baumannii* strains harboring armA from hospitalized patients in Nepal. A methylase gene (armA), conferring high level of resistance to aminoglycosides, was detected in majority of our isolates.

**Keywords:** *Acinetobacter baumannii*; aminoglycosideresistance; 16S rNAMethylase; multidrug-resistant.

### INTRODUCTION

*Acinetobacter baumannii* is a gram-negative, non-lactose-fermenting organism recognized as a major pathogen responsible for nosocomial infections.<sup>1</sup> It plays a significant role in the colonization and infection of hospitalized patients implicating variety of nosocomial infections, particularly in patients admitted to intensive care units.<sup>2</sup>

Methylation of 16S ribosomal RNA (rRNA) has emerged as a new mechanism of resistance to clinically important aminoglycosides among gram-negative pathogens of the family

Enterobacteriaceae and glucose-non-fermenting organisms including *Pseudomonas aeruginosa* and *Acinetobacter* species.<sup>3</sup>

The armA gene encoding a 16S rRNA methylase, was initially identified in *Citrobacter freundii* in 2002 in Poland<sup>4</sup> causing global dissemination of hazardous multiple aminoglycoside resistance genes. Although data on the prevalence of aminoglycoside resistance mediated by 16S rRNA methylation among gram-negative bacilli is still scarce, the presence of 16S rRNA methylases has already been reported worldwide

### METHODS

Correspondence: Shovita Shrestha, Department of Microbiology, Institute of Medicine, Tribhuvan University Teaching Hospital, Kathmandu, Nepal.  
Email: shovitashrestha@gmail.com, Phone: +977-9851098729.

Emergence of Aminoglycoside Resistance Due to armA methylase in Multi-drug Resistant Acinetobacter Baumannii Isolates

This study was approved by Institutional Review Board, Institute of Medicine, Research Department, Kathmandu, Nepal. It is a cross-sectional study, conducted at the Department of Clinical Microbiology, Tribhuvan University Teaching Hospital (TUTH).

From December 2013 to September 2014, two hundred and forty six Acinetobacter spp. were isolated from non-duplicate, non-consecutive samples of blood, wound, urine, sputum and respiratory tract of patients from different wards of TU Teaching hospital in Nepal.

Specimen collection, culture, identification tests were performed according to the guidelines given by American Society of Microbiology (ASM).<sup>5</sup>

Phenotypic identification was performed by conventional biochemical methods.<sup>6</sup> Species identification was confirmed by 16SrRNA sequencing<sup>7</sup> also confirmed for blaOXA-51 genes by PCR.<sup>8</sup>

Drug susceptibility testing was performed by Kirby-Bauer disc diffusion method as recommended by Clinical and Laboratory Standards Institute (CLSI) guidelines 2015.<sup>9</sup> Escherichia coli ATCC 25922 was used as the quality control strain.

Minimum inhibitory concentration (MICs) were performed by broth micro-dilution method and interpreted according to guidelines of the CLSI 2015.<sup>9</sup>

MDR A. baumannii strains are defined as isolates not susceptible to at least one agent in three or more antimicrobial categories, including aminoglycosides, antipseudomonal carbapenems, antipseudomonal fluoroquinolones, antipseudomonal penicillins/ $\beta$ -lactam inhibitors, extended-spectrum cephalosporins, folate pathway inhibitors, penicillins/ $\beta$ -lactamase inhibitors, polymyxins and tetracyclines.<sup>10</sup>

A. baumannii isolates showing resistance to gentamicin and amikacin in disk diffusion were subjected to screen for producing 16 SrRNA methylase.<sup>3</sup>

PCR analysis was done using 16S rRNA methylase gene specific primers to detect the armA, rmtA, rmtB, rmtD genes. The PCR primers used were, for armA, 5'-ATTCTGCCTATCCTAATTGG-3' (forward) and 5'-ACCTATACTTTATCGTCGTC-3' (reverse), which amplify a 315-bp DNA fragment; for rmtA, 5'-CTAGCGTCCATCCTTTCCCTC-3' (forward) and 5'-TTGCTTCCATGCCCTTGCC-3' (reverse), which amplify a 635-bp DNA fragment for rmtB, 5'-ATGAACATCAACGATGCCCTCACC-3' (forward) and

5'-TATCAAGTATATAAGTTCTGTTCGG-3' (reverse), which amplify a 741-bp DNA fragment; and for rmtD, 5'-CGGCACGCGATTGGGAAGC-3' (forward) and 5'-CGGAAACGATGCGACGAT-3' (reverse), which amplify a 401-bp DNA fragment.<sup>4</sup>

## RESULTS

Of the 246 Acinetobacter spp. isolates tested, 129 (52.43%) were multidrug-resistant (MDR). Of the 129 MDR isolates, 122 were A. baumannii, 6 were A. calcoaceticus and 1 was A. bereziniae. The majority of MDR A. baumannii isolates were resistant to at least one agent in 7 or more antimicrobial categories.

One-hundred-nine (89.34%) and 97 (79.50%) isolates showed MICs of  $\geq 512$  mg/L to amikacin and arbekacin respectively. All isolates were resistant to ceftazidime and 119 (97.54%) were resistant to meropenem. All were sensitive to colistin with MICs of  $\leq 2$  mg/L. Ninety isolates (73.77%) had MICs of  $\leq 1$  mg/L to tigecycline, whereas 4 isolates (3.27%) had MICs of 8 mg/L.

Among the total bacterial isolates (n=122), majority was from respiratory tract (n=60, 49.18%) followed by pus/wounds (n=30, 24.59%) and urine (n=13, 10.65%). (Table 1)

**Table 1. Distribution of MDR A. baumannii in various samples (n=122).**

Specimen	No.	%
Respiratory tract	60	49.18
Pus	30	24.59
Urine	13	10.65
Blood	9	7.37
CSF	7	5.73
Others	3	2.45
Total	122	100

Majority of the isolates were resistant to all the antibiotics tested, which is shown in the table below (Table 2). All the isolates were sensitive to polymyxin, colistin and tigecycline

**Table 2. Antimicrobial susceptibility profile of 122 MDR A. baumannii isolates.**

Antibiotic	Resistant, number (%)	Sensitive, number (%)
Ciprofloxacin	122 (100)	0
Ceftriaxone	122 (100)	0
Ceftazidime	122 (100)	0
Gentamicin	120 (98.36)	2 (1.63)
Cefepime	120 (98.36)	2 (1.63)

Emergence of Aminoglycoside Resistance Due to armA methylase in Multi-drug Resistant Acinetobacter Baumannii Isolates

Co-trimoxazole	119 (97.54)	3 (2.45)
Meropenem	119 (97.54)	3 (2.45)
Ampicillin/sulbactam	118 (96.72)	4 (3.27)
Amikacin	117 (95.90)	5 (4.09)
Piperacillin/tazobactam	115 (94.26)	7 (5.73)
Imipenem	97 (79.50)	25(20.49)
Levofloxacin	92 (75.40)	30 (24.59)
Doxycycline	72 (59.01)	50 (40.98)
Colistin	0	122 (100)
Polymyxin	0	122 (100)
Tigecycline	0	122 (100)

Fig 2. Electrophoresis profile of the PCR product of armA genes: laneM- marker, lane1- positive control, lane 2- negative control, lane 3, 5, 7 and 9 - armA positive.

DISCUSSION

Multi-drug resistant *A. baumannii* has been the cause of an increasing threat in hospitals and a global challenge nowadays. *A. baumannii* is an important nosocomial pathogen associated with a wide variety of illnesses in hospitalized patients especially in the intensive care units imposing greater challenge to the patients management and infection control. In our study also majority of the isolates were recovered from patients from ICU (60, 49.18%) followed by surgical ward (22, 18.03%). Antimicrobial resistance among *A. baumannii* has substantially increased in the past decade creating a major public health dilemma. Carbapenems are the most potent antibiotic currently available but resistant strains have emerged.<sup>11</sup>

In our study, *A. baumannii* was frequently isolated from respiratory tract (49.18%) followed by pus (24.59%), urinary tract (10.65%), blood (7.37%), CSF (5.73%) and other sources (2.45%). In another study from India, 59.8% *A. baumannii* isolates were reported from respiratory tract followed by 18.6% from blood.<sup>12</sup>

We have studied the antimicrobial resistance pattern of 122 *A. baumannii* isolates. In our study, *A. baumannii* isolates showed resistance to most of the antibiotic tested. All the isolates were completely sensitive to polymyxin, colistin and tigecycline only.

Aminoglycosides continue to play an important role in the management of serious infections caused by gram-negative pathogens, often in combination with broad-spectrum beta-lactams but the activity of aminoglycosides is lower for MDR isolates of *A. baumannii* compared with non-multiresistant ones. To survive in this niche, *A. baumannii* developed a large variety of resistance traits including production of 16S rRNA methylases with the major representative armA.

Incidence of infection by *A. baumannii* with armA 16S rRNAmethylase has increased, leading to reports of high-level resistance to most aminoglycosides.<sup>13</sup> In our study, the prevalence of armA among MDR *A. baumannii* was 61.47% and the isolates with armA in our study were highly resistant to all available aminoglycosides. According to a study done in Korea, the prevalence of armA among MDR *A. baumannii* was 97.8%<sup>13</sup> which is

Majority of the isolates were from Intensive care unit (ICU) followed by Surgical ward and Medical ward. (Figure 1)

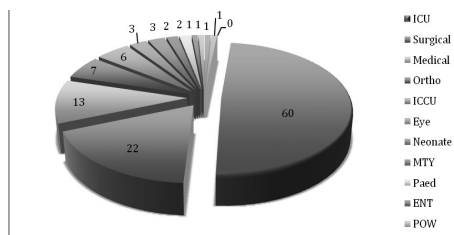
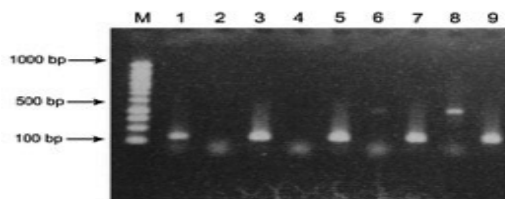

Fig 1. Wardwise distribution of MDR *A. baumannii* (n=122).

Ninety-six of the 122 MDR *A. baumannii* isolates had MICs of > 512 mg/L to amikacin and arbekacin which indicates their high resistance to aminoglycosides. 9 isolates had MICs of >512mg/L to amikacin but <64mg/L to arbekacin. 3 isolates had MICs of 512mg/L to amikacin but <16mg/L to arbekacin. The remaining 14 isolates had MICs of <512mg/L to amikacin and < 64mg/L to arbekacin.

Of the 96 pan-aminoglycoside resistant isolates, 75 isolates had 16SrRNAmethylase with all isolates harboring armA gene. None of the isolates harbored genes other than armA. (Figure 2)





quite higher than our study. Another study done in Egypt found 94% prevalence of armA in clinical isolates of *A. baumannii*.<sup>14</sup>

Antibiotics are among the most commonly prescribed drugs in hospitals. In developed countries around 30% of the hospitalized patients are treated with these drugs.<sup>15</sup> Among the hospitalized patients in a medical settings in Vietnam, 67.4% received antibiotics including 18.9% receiving aminoglycosides with 30.8% inappropriately prescribed.<sup>16</sup> A study done in Nepal documents 29.5% of the patients were prescribed antibiotics. This is very similar to the reports from developed countries.<sup>15</sup> A study done in outpatients of Nepal concludes antibiotics were the most frequently prescribed therapeutic class with 16.54% of the total prescribed drugs.<sup>17</sup>

Nosocomial infections caused by multidrug-resistant, gram-negative bacteria have become a serious problem in clinical facilities. *P. aeruginosa* and *Acinetobacter* spp. have been especially efficient at developing multidrug-resistance against broad-spectrum  $\beta$ -lactams, fluoroquinolones, and aminoglycosides. The identification of armA and rmtB genes in Europe and East Asia suggests that we must pay consistent attention to prevent further global proliferation. If 16S rRNA methylase positive bacterial isolates disseminate widely and extensively, the high level of pan-aminoglycoside resistance will undoubtedly have an impact on illness, deaths, and costs of care.<sup>18</sup>

To our knowledge, this is the first report of 16S rRNA methylase in *A. baumannii* isolates causing high level of resistant to aminoglycosides in medical settings in Nepal. Some of the *A. baumannii* strains were simultaneously resistant to other classes of antimicrobials including carbapenems. The high prevalence of 16S rRNA methylase producing MDR *A. baumannii* in our hospital would have resulted from the high rate of the use of aminoglycosides.

Our study strongly suggests that *A. baumannii* isolates producing a 16S rRNA methylase, armA, have emerged and disseminated in Nepal. A methylase gene (armA), which confers high levels of resistance to aminoglycosides, was detected in the majority of our isolates. This suggests that aminoglycosides may no longer be recommended as a first-line treatment for multidrug resistant *A. baumannii* infections in our settings.

## CONCLUSIONS

This is the first report describing the presence of methylase producing MDRA. *baumannii* in medical

settings in Nepal. Multidrug resistant *A. baumannii* were common in our hospital and they usually harbored 16S rRNA methylase gene, predominantly armA.

The high prevalence of armA can threaten the existing therapeutic qualities for such infections. Strict surveillance and more rapid detection are essential to reduce the spread of MDRA. *baumannii* including 16S rRNA methylase.

## ACKNOWLEDGEMENTS

Authors would like to offer their sincere gratitude to all the staffs of the Department of Microbiology and different wards as well as all the lab members of National Center for Global Health and Medicine, NCGM, Tokyo. We are grateful to National Academy of Science and Technology (NAST) for providing fellowship grant for this study. Also we would like to thank all the patients of TUTH for their generous support throughout the study.

## REFERENCES

1. Peleg AY, Seifert H, Paterson DL. *Acinetobacter baumannii*: Emergence of a successful pathogen. *Clin Microbiol Rev.* 2008;21(3):538-582. doi:10.1128/CMR.00058-07.
2. Bergogne-Bérézin E, Towner KJ. *Acinetobacter* spp. as nosocomial pathogens: Microbiological, clinical, and epidemiological features. *Clin Microbiol Rev.* 1996;9(2):148-165.
3. Doi Y, Arakawa Y. 16S Ribosomal RNA Methylation : Emerging Resistance Mechanism against Aminoglycosides. 2007;45. doi:10.1086/518605.
4. Tada T, Miyoshi-Akiyama T, Shimada K, Shimojima M, Kirikae T. Dissemination of 16S rRNA methylase armA-producing *Acinetobacter baumannii* and emergence of OXA-72 carbapenemase co-producers in Japan. *Antimicrob Agents Chemother.* 2014;58(5):2916-2920. doi:10.1128/AAC.01212-13.
5. Isenberg HD. *Clinical Microbiology Procedures Handbook*. 2nd ed. Washington D.C., ASM Press.
6. Shahcheraghi F, Abbasalipour M, Feizabadi MM, Ebrahimipour GH, Akbari N. Isolation and genetic characterization of metallo- $\beta$ -lactamase and carbapenemase producing strains of *Acinetobacter baumannii* from patients at tehran hospitals. *Iran J Microbiol.* 2011;3(2):68-74.
7. Clarridge JE, Alerts C. Impact of 16S rRNA gene sequence analysis for identification of bacteria on clinical

- microbiology and infectious diseases. *Clin Microbiol Rev.* 2004;17(4):840-862. doi:10.1128/CMR.17.4.840.
8. Turton JF, Woodford N, Glover J, Yarde S, Kaufmann ME, Pitt TL. Identification of *Acinetobacter baumannii* by detection of the bla OXA-51-like carbapenemase gene intrinsic to this species. *J Clin Microbiol.* 2006;44(8):2974-2976. doi:10.1128/JCM.01021-06.
  9. CLinical and Laboratory Standards Institute. Performance standards for antimicrobial disk susceptibility testing, 17th informational supplement. Wayne, PA, M100-S17, 2007
  10. Magiorakos AP, Srinivasan A, Carey RB, Carmeli Y, Falagas ME, Monnet DL. Multidrug-resistant, extensively drug-resistant and pandrug-resistant bacteria: An international expert proposal for interim standard definitions for acquired resistance. *Clin Microbiol Infect.* 2012;18(3):268-281. doi:10.1111/j.1469-0691.2011.03570.x.
  11. Shrestha S, Tada T, Shrestha B, Kirikae T, Pokhrel BM, Sherchand JB. Phenotypic characterization of multidrug-resistant *Acinetobacter baumannii* with special reference to metallo- $\beta$ -lactamase production from the hospitalized patients in a tertiary care hospital in Nepal. *J Inst Med (Nepal)* 2015;37 (3):3-10
  12. Jaggi N, Sissodia P, Sharma L. *Acinetobacter baumannii* isolates: epidemiology, antibiogram and nosocomial status studied over a 25 month period in a tertiary care hospital in India. *BMC Proc.* 2011;5(Suppl 6):P291. doi:10.1186/1753-6561-5-S6-P291.
  13. Lim J, Cho HH, Kim S, et al. The genetic characteristics of multidrug-resistant *Acinetobacter baumannii* coproducing 16S rRNA methylase armA and carbapenemase OXA-23. *J Bacteriol Virol.* 2013;43(1):27-36. doi:10.4167/jbv.2013.43.1.27.
  14. Ahmed ES, Amin MA, Tawakol WM, Loucif L, Bakour S, Rolain JM. High prevalence of blaNDM-1 carbapenemase-encoding gene and 16S rRNA armA methyltransferase gene among *Acinetobacter baumannii* clinical isolates in Egypt. *Antimicrob Agents Chemother.* 2015;59(6):3602-3605. doi:10.1128/AAC.04412-14.
  15. Shankar RP, Partha P, Shenoy NK, Easow JM, Brahmadathan KN. Prescribing patterns of antibiotics and sensitivity patterns of common microorganisms in the Internal Medicine ward of a teaching hospital in Western Nepal: a prospective study. *Ann Clin Microbiol Antimicrob.* 2003;2:7. doi:10.1186/1476-0711-2-7.
  16. Tada T, Akiyama TM, Kato Y, Ohmagari V, Takeshita N, Kirikae T. Emergence of 16S rRNA methylase-producing *Acinetobacter baumannii* and *Pseudomonas aeruginosa* isolates in hospitals in Vietnam. *BMC Infect Dis.* 2013;13(1):1-6. doi:10.1186/1471-2334-13-251.
  17. Kumar J, Shaik M, Kathi M, Deka A, Gambhir S. Prescribing indicators and pattern of use of antibiotics among medical outpatients in a teaching hospital of Central Nepal. *J Coll Med Sci.* 2010;6(2):7-13. doi:10.3126/jcmsn.v6i2.3610.
  18. Yamane K, Wachino J, Suzuki S, Shibata N, Kato H, Arakawa Y. 16S rRNA methylase-producing, gram-negative pathogens, Japan. *Emerg Infect Dis.* 2007;13. doi:10.3201/eid1304.060501.



## Comparative Genome Analysis of Extended-Spectrum- $\beta$ -Lactamase-Producing *Escherichia coli* Sequence Type 131 Strains from Nepal and Japan

Tohru Miyoshi-Akiyama,<sup>a</sup> Jatan Bahadur Sherchan,<sup>b</sup> Yohei Doi,<sup>c</sup> Maki Nagamatsu,<sup>d,e</sup> Jeevan B. Sherchand,<sup>f</sup> Sarmila Tandukar,<sup>f</sup> Norio Ohmagari,<sup>d</sup> Teruo Kirikae,<sup>e</sup> Hiroshi Ohara,<sup>g</sup> Kayoko Hayakawa<sup>d</sup>

Pathogenic Microbe Laboratory, Research Institute, National Center for Global Health and Medicine, Tokyo, Japan<sup>a</sup>; Department of Clinical Microbiology, Kathmandu University School of Medical Sciences, Dhulikhel, Nepal<sup>b</sup>; Division of Infectious Diseases, University of Pittsburgh School of Medicine, Pittsburgh, Pennsylvania, USA<sup>c</sup>; Disease Control and Prevention Center, National Center for Global Health and Medicine, Tokyo, Japan<sup>d</sup>; Department of Infectious Diseases, Research Institute, National Center for Global Health and Medicine, Tokyo, Japan<sup>e</sup>; Public Health Research Laboratory, Institute of Medicine, Tribhuvan University Teaching Hospital, Kathmandu, Nepal<sup>f</sup>; Department of International Medical Cooperation, National Center for Global Health and Medicine, Tokyo, Japan<sup>g</sup>

**ABSTRACT** The global spread of extended-spectrum- $\beta$ -lactamase (ESBL)-producing *Escherichia coli* (ESBL-*E. coli*) has largely been driven by the pandemic sequence type 131 (ST131). This study aimed to determine the molecular epidemiology of their spread in two Asian countries with contrasting prevalence. We conducted whole-genome sequencing (WGS) of ESBL-*E. coli* ST131 strains collected prospectively from Nepal and Japan, two countries in Asia with a high and low prevalence of ESBL-*E. coli*, respectively. We also systematically compared these genomes with those reported from other regions using publicly available WGS data for *E. coli* ST131 strains. Further, we conducted phylogenetic analysis of these isolates and all genome sequence data for ST131 strains to determine sequence diversity. One hundred five unique ESBL-*E. coli* isolates from Nepal (February 2013 to July 2013) and 76 isolates from Japan (October 2013 to September 2014) were included. Of these isolates, 54 (51%) isolates from Nepal and 11 (14%) isolates from Japan were identified as ST131 by WGS. Phylogenetic analysis based on WGS suggested that the majority of ESBL-*E. coli* ST131 isolates from Nepal clustered together, whereas those from Japan were more diverse. Half of the ESBL-*E. coli* ST131 isolates from Japan belonged to virotype C, whereas half of the isolates from Nepal belonged to a virotype other than virotype A, B, C, D, or E (A/B/C/D/E). The dominant sublineage of *E. coli* ST131 was H30Rx, which was most prominent in ESBL-*E. coli* ST131 isolates from Nepal. Our results revealed distinct phylogenetic characteristics of ESBL-*E. coli* ST131 spread in the two geographical areas of Asia, indicating the involvement of multiple factors in its local spread in each region.

**IMPORTANCE** The global spread of ESBL-*E. coli* has been driven in large part by pandemic sequence type 131 (ST131). A recent study suggested that, within *E. coli* ST131, certain sublineages have disseminated worldwide with little association with their geographical origin, highlighting the complexity of the epidemiology of this pandemic clone. ST131 bacteria have also been classified into four virotypes based on the distribution of certain virulence genes. Information on virotype distribution in Asian ST131 strains is limited. We conducted whole-genome sequencing of ESBL-*E. coli* ST131 strains collected in Nepal and Japan, two Asian countries with a high and low prevalence of ESBL-*E. coli*, respectively. We systematically compared these ST131 genomes with those reported from other regions to gain insights into the molecular

Received 28 September 2016 Accepted 29 September 2016 Published 26 October 2016

**Citation** Miyoshi-Akiyama T, Sherchan JB, Doi Y, Nagamatsu M, Sherchand JB, Tandukar S, Ohmagari N, Kirikae T, Ohara H, Hayakawa K. 2016. Comparative genome analysis of extended-spectrum- $\beta$ -lactamase-producing *Escherichia coli* sequence type 131 strains from Nepal and Japan. *mSphere* 1(5):e00289-16. doi:10.1128/mSphere.00289-16.

**Editor** Patricia A. Bradford, Antimicrobial Development Specialists, LLC

**Copyright** © 2016 Miyoshi-Akiyama et al. This is an open-access article distributed under the terms of the Creative Commons Attribution 4.0 International license.

Address correspondence to Kayoko Hayakawa, kayokohayakawa@gmail.com.

Downloaded from <http://msphere.asm.org/> on December 26, 2017 by guest

epidemiology of their spread and found the distinct phylogenetic characteristics of the spread of ESBL-*E. coli* ST131 in these two geographical areas of Asia.

**KEYWORDS:** CTX-M, *Escherichia coli*, ST131, antimicrobial resistance, extended-spectrum beta-lactamase, whole-genome sequence

The emergence of extended-spectrum-β-lactamase (ESBL)-producing *Escherichia coli* (ESBL-*E. coli*) is a global problem. However, its prevalence and epidemiology differ significantly depending on its geographical location. According to a recent report from the World Health Organization (WHO) (1), the prevalences of *E. coli* resistance to third-generation cephalosporins were 14% in Europe, 27% in the Americas (15% in the United States), and 30% in Southeast Asia. The prevalence of *E. coli* resistance to these cephalosporins was the highest in developing countries in Asia (38% in Nepal, 68% in Myanmar, and 16% to 95% in India) while relatively low in more-developed Asian countries, including Japan (17%) (1).

The global spread of ESBL-*E. coli* has been driven in large part by pandemic sequence type 131 (ST131); *E. coli* ST131 bacteria are often resistant to multiple drugs (2). A recent study suggested that, within *E. coli* ST131, certain sublineages have disseminated worldwide with little association with their geographical origin, highlighting the complexity of the epidemiology of this pandemic clone (3). ST131 has also been classified into four virotypes based on the distribution of certain virulence genes, and virotype C has been reported to be globally disseminated (4). However, information pertaining to virotype distribution among Asian ST131 strains is limited.

In this study, we conducted whole-genome sequencing (WGS) of ESBL-*E. coli* ST131 strains collected prospectively in Nepal (5) and Japan. Although both countries are located in Asia, the socioeconomic statuses of Japan and Nepal are different and they also have distinct prevalences of ESBL-*E. coli* (Japan has a low prevalence, and Nepal has a high prevalence). We systematically compared these ST131 genomes with those reported from other regions to gain insights into the epidemiology of their spread.

## RESULTS AND DISCUSSION

**Characteristics of ESBL-*E. coli* ST131 isolates and *E. coli* ST131 genomes.** During the study period, 105 and 76 unique ESBL-*E. coli* isolates were identified from Nepal and Japan, respectively. Of these isolates, 54 (51%) isolates from Nepal and 11 (14%) isolates from Japan were identified as ST131 by WGS based on sequence typing and included in further analyses. Forty (38.1%) of 105 ESBL-*E. coli* isolates from Nepal and 19 (25%) of 76 ESBL-*E. coli* isolates from Japan were isolated from outpatients. Nineteen (35.2%) of 54 ESBL-*E. coli* ST131 isolates from Nepal and 2 (18.2%) of 11 of ESBL-*E. coli* ST131 isolates from Japan were from outpatients. This suggests that ESBL-*E. coli* ST131 bacteria were isolated from outpatients almost twice as often in Nepal as in Japan.

The median age of patients with ESBL-*E. coli* ST131 was significantly lower in Nepal (39 years [interquartile range (IQR), 25 to 61 years]) than in Japan (83 years [IQR, 73 to 86 years]) ( $P < 0.001$ ). The numbers of male patients with ESBL-*E. coli* ST131 were similar in the two countries (19 [35%] in Nepal and 4 in Japan [36%]). The majority of isolates were collected from urine samples (54 [100%] in Nepal and 8 [73%] in Japan). Pregnant female patients with ESBL-*E. coli* ST131 were more frequent in Nepal ( $n = 9$  [26%]) than in Japan ( $n = 0$ ) ( $P < 0.001$ ). Comorbid conditions, such as malignancy ( $n = 2$  [3.7%] in Nepal;  $n = 3$  [27.3%] in Japan) and underlying urological conditions (e.g., benign prostatic hyperplasia, urolithiasis, obstructive urinary diseases) ( $n = 10$  [18.5%] in Nepal;  $n = 6$  [54.5%] in Japan) were more common in patients with ESBL-*E. coli* in Japan than in patients in Nepal ( $P = 0.031$  and  $P = 0.02$ , respectively). ESBL-*E. coli* isolates from Nepal and Japan had distinct clinical characteristics.

In a study that identified ESBL-*E. coli* from travelers who returned from India, 47% of 17 ESBL-*E. coli* isolates collected from 2004 to 2006 were ST131 (6). The prevalence of ST131 among ESBL-*E. coli* bacteria isolated in Nepal in our study is in line with the previous data, considering the geographical proximity and traffic of visitors between

**TABLE 1** Comparison of *fimH* alleles and *H30Rx* and *H30R* sublineages in *Escherichia coli* ST131

<i>fimH</i> allele or sublineage	Total no. of isolates (n = 132)	No. of isolates (%) from:						P value <sup>d</sup>
		Nepal (n = 54)	Japan (n = 12) <sup>a</sup>	Other Asian countries (n = 3) <sup>b</sup>	USA (n = 29) <sup>b</sup>	Europe (n = 29) <sup>b,c</sup>	Africa (n = 5) <sup>b</sup>	
<i>H30</i>	110	54 (100)	11 (91.7)	3 (100)	27 (93.1)	12 (41.4)	3 (60)	<0.001
<i>H30Rx</i>	88	54 (100)	8 (66.7)	2 (66.7)	16 (55.2)	6 (20.7)	2 (40)	<0.001
<i>H30R</i> (non-Rx)	19	0 (0)	3 (25)	1 (33.3)	11 (37.9)	3 (10.3)	1 (20)	0.006
<i>H22</i>	9	0 (0)	0 (0)	0 (0)	0 (0)	9 (31)	0 (0)	<0.001
<i>H27</i>	2	0 (0)	0 (0)	0 (0)	0 (0)	0 (0)	2 (40)	<0.001
<i>H41</i>	11	0 (0)	1 (8.3)	0 (0)	2 (6.9)	8 (27.6)	0 (0)	0.001

<sup>a</sup>Includes one publicly available sequence of *E. coli* ST131.

<sup>b</sup>Publicly available sequence data for *E. coli* ST131.

<sup>c</sup>One isolate from Austria belonged to *H31*.

<sup>d</sup>The P values are comparing the prevalence of each antibiotic resistance gene among geographical regions. P values in boldface type represent statistically significant results.

Nepal and India. The ST131 prevalence of 14% found among ESBL-*E. coli* isolates from Japan is also similar to that reported in a previous study where 21% of 130 ESBL-*E. coli* isolates collected between 2002 and 2003 from Japan were ST131 (7). However, the prevalence was lower than that reported in a more recent study conducted in Japan, in which 37% of 581 ESBL-*E. coli* isolates collected from 2001 to 2010 were identified as ST131 (8). This discrepancy might be attributed to the differences in the year of collection, geographical locations in the country, and methods used to identify ST131 (PCR-based screening versus WGS).

***fimH* alleles and *H30Rx* sublineages in *E. coli* ST131.** *fimH* alleles and *H30Rx* sublineages in *E. coli* ST131 were determined and compared among various geographical regions (Table 1). *fimH30*, especially *fimH30Rx* comprised the majority of the *fimH* alleles in various geographical regions, followed by *fimH41* and *fimH22*. *fimH27* was observed only in *E. coli* ST131 from Africa. We found that all 54 ESBL-*E. coli* isolates from Nepal belonged to the *H30Rx* sublineage. There is little data on the prevalence of the *H30Rx* sublineage in South Asia. A previous study that included only a few ST131 strains from India revealed that all of them belonged to clade C (i.e., *H30*) and produced CTX-M-15 (3). Our result is in accordance with the high prevalence of CTX-M-15-producing ESBL-*E. coli* reported among travelers returning from the Indian subcontinent (6). However, the limited isolate collection period in one facility might have affected the clonal distribution of ESBL-*E. coli* ST131 isolates from Nepal in our study. *H30R* (non-Rx) were more prevalent among ESBL-*E. coli* ST131 isolates from Japan compared to isolates from Nepal, although more than 60% of ESBL-*E. coli* ST131 isolates from Japan still belonged to *H30Rx*. A previous report from Japan suggested a higher prevalence of *H30R* (non-Rx) and *H22* among ESBL-*E. coli* ST131 isolates collected from 2001 to 2012 in 10 Japanese acute-care hospitals located in Kyoto, Shiga area, which is more than 460 km (286 miles) away from the hospital in this study (9). The relatively high prevalence of *H30R* (non-Rx) and *H22* observed in this study in the United States and Europe, respectively, were consistent with previous reports (3, 10).

**Antimicrobial susceptibility and antibiotic resistance genes.** Antimicrobial susceptibility data were available for 54 and 11 ESBL-*E. coli* ST131 isolates from Nepal and Japan, respectively (Fig. 1). The susceptibilities of the 105 ESBL-*E. coli* isolates (including 54 ESBL-*E. coli* ST131 isolates described in this study) from Nepal were described elsewhere (5). The susceptibilities to trimethoprim-sulfamethoxazole, gentamicin, and levofloxacin were not significantly different in isolates from Nepal and Japan. All ESBL-*E. coli* ST131 isolates from Nepal and Japan were susceptible to cefmetazole and fosfomycin.

The frequency of resistance genes among the *E. coli* ST131 isolates is summarized in Table 2. More than 94% ( $n = 51$ ) and 66% ( $n = 8$ ) of ESBL-*E. coli* ST131 isolates were positive for *bla*<sub>CTX-M-15</sub> in Nepal and Japan, respectively. Overall, 50 (70%) of the 71 *bla*<sub>CTX-M-15</sub>-positive isolates in the entire cohort were also positive for *bla*<sub>OXA-1</sub> and

Miyoshi-Akiyama et al.

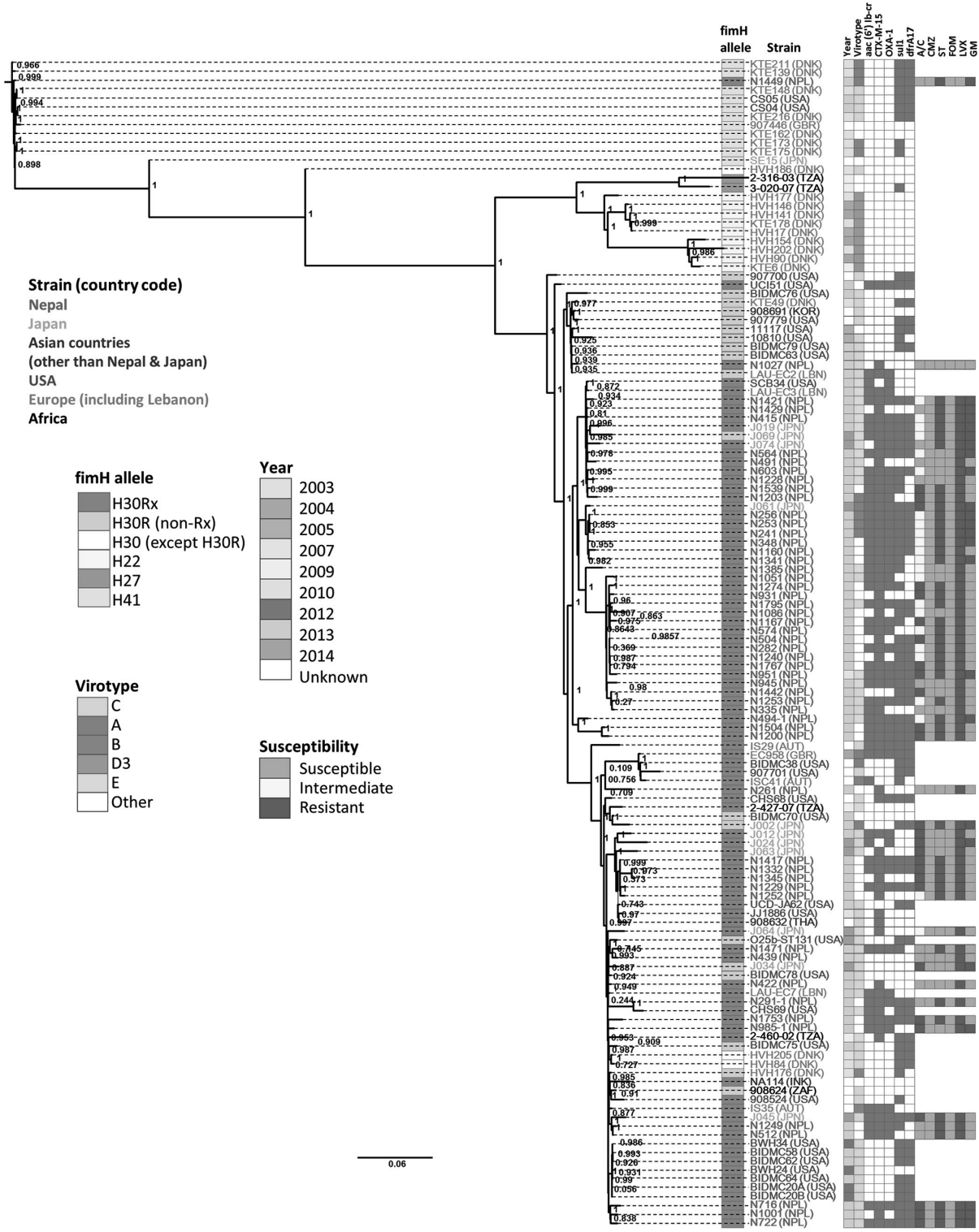

Downloaded from <http://msphere.asm.org/> on December 26, 2017 by guest

**FIGURE 1** Phylogenetic trees of ST131 strains. ML phylogenetic trees were estimated using PHYML 3.0 and SH statistics for branch support. Antibiotics are abbreviated as follows: A/C, amoxicillin and clavulanate; CMZ, cefmetazole; ST, trimethoprim-sulfamethoxazole; FOM, fosfomycin; LVX, levofloxacin; (Continued)

*aac(6′)-Ib-cr* (encoding an aminoglycoside/fluoroquinolone acetyltransferase); of these 71 isolates, 38 isolates were obtained from Nepal, 5 isolates from Japan, and 6 isolates from Europe.

The aforementioned study from Japan (9) revealed higher prevalence of *bla*<sub>CTX-M-14</sub> and *bla*<sub>CTX-M-27</sub> in addition to *bla*<sub>CTX-M-15</sub> among ESBL-*E. coli* isolates collected from another area in Japan. A study from Korea on *E. coli* isolates collected from 2012 to 2013 suggested that the majority of H30Rx isolates harbored *bla*<sub>CTX-M-15</sub>, whereas about half of the H30 non-Rx isolates harbored *bla*<sub>CTX-M-14</sub> or *bla*<sub>CTX-M-27</sub> (11). Geographical differences and different times of these studies may account for these discrepancies.

**Virotypes and virulence-associated genes.** The distribution of virotypes and virulence-associated genes among the *E. coli* ST131 strains is summarized in Table 3. The predominant virotypes differed across the geographical regions. The majority of *E. coli* ST131 isolates from the United States and half of those from Japan belonged to virotype C, whereas almost half of the isolates from Nepal belonged to virotypes other than A, B, C, D, and E. Two-thirds of *E. coli* ST131 isolates from Europe belonged to either virotype C or D. The virulence-associated genes such as *iha*, *sat*, *fyuA*, *traT*, *ompT*, and *malT* were highly prevalent among isolates from most geographical regions. The *papGII* gene was frequently observed only among isolates from Nepal and Tanzania, and *hlyA* and *cnf1* were common only in *E. coli* ST131 isolates obtained from Africa. Most of the virotypes obtained in our study belonged to virotype C (Table 1). Our finding that virotype C is the most prevalent virotype among *E. coli* ST131 isolates is consistent with previous reports on virotype distribution in ESBL-*E. coli* ST131 (4, 12). As previously suggested (4, 12), our results also suggested the association between virotype C and H30Rx sublineage. In our study, more isolates were identified as “other” virotype than previous studies (4, 12), which might be due to the different methodology used (e.g., WGS versus PCR). The majority of the ESBL-*E. coli* ST131 isolates ( $n = 28$  [52%]) from Nepal were positive for *papGII* and *sat* but were negative for *hlyA*, and thus, were not categorized into any of the previously described virotypes (A to E) (13).

**Plasmid replicon types.** The distribution of plasmid replicon types was similar across geographical regions except that FIA was prevalent in Nepal and the United States and considerably less prevalent in Europe; other geographical regions showed intermediate prevalence (Table 4). FII was commonly found among ESBL-*E. coli* ST131 isolates from Nepal, whereas it was considerably less prevalent in Japan. IncP was detected in 40% of *E. coli* ST131 isolates from Africa, but it was very rarely found or not found in isolates from other areas.

The association of *bla*<sub>CTX-M-15</sub> and IncF replicon has been reported previously (14), and the H30Rx sublineage was created by introduction of IncF (15). We previously found that a plasmid resembling pEC958 and harboring FIA and FII (16) was present in approximately 80% of the ESBL-*E. coli* ST131 isolates from Nepal (5). The high prevalence of IncF (IncFIA, FIB, and FII) observed among ESBL-*E. coli* ST131 isolates from Nepal is consistent with these previous reports and is reasonable considering the high prevalence of H30Rx among ESBL-*E. coli* ST131 isolates.

**Phylogenetic analysis of *E. coli* ST131 in different geographical regions.** In the phylogenetic analysis based on WGS (Fig. 1), the majority of ESBL-*E. coli* ST131 isolates from Nepal clustered together, whereas those from Japan were more diverse. Thus, ESBL-*E. coli* ST131 may have been introduced into Japan more sporadically over time. Strict requirements for antibiotic prescription in Japan might have resulted in relatively low selective pressure, along with more advanced medical and social infrastructure. Carriers of ESBL-*E. coli* are usually placed under contact precaution in health

#### Figure Legend Continued

GM, gentamicin. The countries are shown in parentheses after the strain name and abbreviated as follows: DNK, Denmark; NPL, Nepal; GBR, Great Britain; JPN, Japan; TZA, Tanzania; KOR, South Korea; LBN, Lebanon; AUT, Austria; THA, Thailand. Susceptibility data are available only for the 11 ESBL-*E. coli* ST131 isolates from the National Center for Global Health and Medicine, Japan, and 54 ESBL-*E. coli* ST131 isolates from Tribhuvan University, Nepal. For isolates from Japan, ampicillin-sulbactam was used instead of amoxicillin-clavulanate. For resistance genes, a filled square means positive for the resistance gene and an open square means negative for the resistance gene.

**TABLE 2** Comparison of resistance genes in *Escherichia coli* ST131

Antibiotic(s) and antibiotic resistance gene	<i>fimH</i> allele or sublineage	Total no. of isolates (n = 132)	No. of isolates (%) from:					P value <sup>d</sup>	
			Nepal (n = 54)	Japan (n = 12) <sup>a</sup>	Other Asian countries (n = 3) <sup>b</sup>	USA (n = 29) <sup>b</sup>	Europe (n = 29) <sup>b,c</sup>		Africa (n = 5) <sup>b</sup>
<b>Aminoglycoside</b>									
<i>aac(3)-IIa</i>	Total	26	15 (27.8)	5 (41.7)	0	3 (10.3)	3 (10.3)	0	0.05
	H30Rx	25	15 (27.8)	4 (33.3)		3 (10.3)	3 (10.3)		
	H30R	1		1 (8.3)					
<i>aac(3)-IIId</i>	Total	17	1 (1.9)	2 (16.7)	1 (33.3)	5 (17.2)	5 (17.2)	3 (60)	<b>0.003</b>
	H30Rx	3	1 (1.9)			1 (3.4)		1 (20)	
	H30R	6		2 (16.7)	1 (33.3)	2 (6.9)		1 (20)	
	H27	1						1 (20)	
	H41	7				2 (6.9)	5 (17.2)		
<i>aadA1</i>	Total	5	0	0	0	2 (6.9)	3 (10.3)	0	0.213
	H30Rx	1					1 (3.4)		
	H30R	3				2 (6.9)	1 (3.4)		
	H41	1					1 (3.4)		
<i>aadA2</i>	Total	11	8 (14.8)	0	0	2 (6.9)	1 (3.4)	0	0.329
	H30Rx	8	8 (14.8)						
	H30R	3				2 (6.9)	1 (3.4)		
<i>aadA5</i>	Total	68	31 (57.4)	6 (50)	0	21 (72.4)	9 (31)	1 (20)	<b>0.007</b>
	H30Rx	51	31 (57.4)	4 (33.3)		13 (44.8)	2 (6.9)	1 (20)	
	H30R	9		2 (16.7)		6 (20.7)	1 (3.4)		
	H41	8				2 (6.9)	4 (13.8)		
	H27	2						2 (40)	
<i>strA</i>	Total	45	20 (37)	2 (16.7)	1 (33.3)	13 (44.8)	6 (20.7)	3 (60)	0.211
	H30Rx	28	20 (37)	1 (8.3)		6 (20.7)		1 (20)	
	H30R	7		1 (8.3)	1 (33.3)	5 (17.2)			
	H27	2						2 (40)	
	H41	8				2 (6.9)	6 (20.7)		
<i>strB</i>	Total	49	20 (37)	2 (16.7)	1 (33.3)	15 (51.7)	7 (24.1)	4 (80)	0.054
	H30Rx	30	20 (37)	1 (8.3)		8 (27.6)		1 (20)	
	H30R	3		1 (8.3)	1 (33.3)			1 (20)	
	H22	5				5 (17.2)		2 (40)	
	H27	2							
	H41	9				2 (6.9)	7 (24.1)		
<b>Aminoglycoside and fluoroquinolone</b>									
<i>aac(6)-Ib-cr</i>	Total	55	39 (72.2)	6 (50)	0	3 (10.3)	7 (24.1)	0	<b>&lt;0.001</b>
	H30Rx	53	39 (72.2)	5 (41.7)		3 (10.3)	6 (20.7)		
	H30R	2		1 (8.3)			1 (3.4)		
<b>Beta-lactams</b>									
<i>bla<sub>CTX-M-14</sub></i>	Total	2	0	0	0	0	2 (6.9)	0	0.205
	H41	2					2 (6.9)		
<i>bla<sub>CTX-M-15</sub></i>	Total	71	51 (94.4)	8 (66.7)	1 (33.3)	4 (13.8)	6 (20.7)	1 (20)	<b>&lt;0.001</b>
	H30Rx	69	51 (94.4)	7 (58.3)	1 (33.3)	4 (13.8)	5 (17.2)	1 (20)	
	H30R	2		1 (8.3)			1 (3.4)		
<i>bla<sub>CTX-M-27</sub></i>	Total	3	2 (3.7)	0	0	1 (3.4)	0	0	0.874
	H30Rx	2	2 (3.7)						
	H30R	1				1 (3.4)			
<i>bla<sub>CTX-M-55</sub></i>	Total	4	0	3 (25)	1 (33.3)	0	0	0	<b>&lt;0.001</b>
	H30Rx	1		1 (8.3)					
	H30R	3		2 (16.7)	1 (33.3)				
<i>bla<sub>OXA-1</sub></i>	Total	54	38 (70.4)	7 (58.3)	0	3 (10.3)	6 (20.7)	0	<b>&lt;0.001</b>
	H30Rx	52	38 (70.4)	6 (50)		3 (10.3)	5 (17.2)		
	H30R	2		1 (8.3)			1 (3.4)		
<i>bla<sub>TEM-1B</sub></i>	Total	61	20 (37)	3 (25)	1 (33.3)	16 (55.2)	16 (55.2)	5 (100)	<b>0.036</b>
	H30Rx	33	20 (37)	1 (8.3)		6 (20.7)	4 (13.8)	2 (40)	
	H30R	13		2 (16.7)	1 (33.3)	8 (27.6)	1 (3.4)	1 (20)	
	H22	1					1 (3.4)		
	H27	2						2 (40)	
	H41	10				2 (6.9)	8 (27.6)		
<i>bla<sub>TEM-1C</sub></i>	Total	3	0	0	0	0	3 (10.3)	0	0.05
	H22	3					3 (10.3)		

(Continued on following page)

Downloaded from <http://msphere.asm.org/> on December 26, 2017 by guest



TABLE 2 (Continued)

Antibiotic(s) and antibiotic resistance gene	<i>fimH</i> allele or sublineage	Total no. of isolates (n = 132)	No. of isolates (%) from:						P value <sup>d</sup>
			Nepal (n = 54)	Japan (n = 12) <sup>a</sup>	Other Asian countries (n = 3) <sup>b</sup>	USA (n = 29) <sup>b</sup>	Europe (n = 29) <sup>b,c</sup>	Africa (n = 5) <sup>b</sup>	
<i>bla</i> <sub>KPC-3</sub>	Total	6	0	0	0	6 (20.7)	0	0	<b>&lt;0.001</b>
	<i>H30Rx</i>	6				6 (20.7)			
Macrolide <i>mphA</i>	Total	69	46 (85.2)	5 (41.7)	0	10 (34.5)	8 (27.6)	0	<b>&lt;0.001</b>
	<i>H30Rx</i>	56	46 (85.2)	3 (25)		5 (17.2)	2 (6.9)		
	<i>H30R</i>	7		2 (16.7)		4 (13.8)	1 (3.4)		
	<i>H41</i>	4				1 (3.4)	3 (10.3)		
Chloramphenicol <i>catA1</i>	Total	4	0	0	0	0	2 (6.9)	2 (40)	<b>&lt;0.001</b>
	<i>H30Rx</i>	1						1 (20)	
	<i>H27</i>	1						1 (20)	
	<i>H41</i>	2					2 (6.9)		
<i>catB3</i>	Total	51	37 (68.5)	6 (50)	0	2 (6.9)	6 (20.7)	0	<b>&lt;0.001</b>
	<i>H30Rx</i>	48	37 (68.5)	5 (41.7)		1 (3.4)	5 (17.2)		
	<i>H30R</i>	3		1 (8.3)		1 (3.4)	1 (3.4)		
Sulfonamide <i>sul1</i>	Total	82	39 (72.2)	6 (50)	0	22 (75.9)	13 (44.8)	2 (40)	<b>0.01</b>
	<i>H30Rx</i>	60	39 (72.2)	4 (33.3)		13 (44.8)	3 (10.3)	1 (20)	
	<i>H30R</i>	11		2 (16.7)		7 (24.1)	2 (6.9)		
	<i>H27</i>	1						1 (20)	
	<i>H41</i>	8				2 (6.9)	6 (20.7)		
	<i>sul2</i>	Total	52	20 (37)	2 (16.7)	1 (33.3)	18 (62.1)	8 (27.6)	
<i>H30Rx</i>	32	20 (37)	1 (8.3)		9 (31)	1 (3.4)	1 (20)		
<i>H30R</i>	9		1 (8.3)	1 (33.3)	7 (24.1)				
<i>H27</i>	2						2 (40)		
<i>H41</i>	9				2 (6.9)	7 (24.1)			
Trimethoprim <i>dfrA12</i>	Total	8	8 (14.8)	0	0	0	0	0	<b>0.031</b>
	<i>H30Rx</i>	8	8 (14.8)						
<i>dfrA17</i>	Total	67	31 (57.4)	6 (50)	0	20 (69)	9 (31)	1 (20)	<b>0.014</b>
	<i>H30Rx</i>	50	31 (57.4)	4 (33.3)		12 (41.3)	2 (6.9)	1 (20)	
	<i>H30R</i>	9		2 (16.7)		6 (20.7)	1 (3.4)		
	<i>H41</i>	6				2 (6.9)	4 (13.8)		
<i>dfrA1</i>	Total	5	0	0	0	1 (3.4)	4 (13.8)	0	0.054
	<i>H30Rx</i>	1					1 (3.4)		
	<i>H30R</i>	1				1 (3.4)			
	<i>H22</i>	1					1 (3.4)		
	<i>H41</i>	2					2 (6.9)		
Tetracycline <i>tet(A)</i>	Total	86	40 (74.1)	8 (66.7)	1 (33.3)	18 (62.1)	15 (51.7)	4 (80)	0.292
	<i>H30Rx</i>	61	40 (74.1)	7 (58.3)		11 (37.9)	2 (6.9)	1 (20)	
	<i>H30R</i>	10		1 (8.3)	1 (33.3)	5 (17.2)	2 (6.9)	1 (20)	
	<i>H22</i>	4					4 (13.8)		
	<i>H27</i>	2						2 (40)	
	<i>H41</i>	9				2 (6.9)	7 (24.1)		

<sup>a</sup>Includes one publicly available sequence of *E. coli* ST131.

<sup>b</sup>Publicly available sequence data for *E. coli* ST131.

<sup>c</sup>Three isolates from Europe were from Lebanon.

<sup>d</sup>The P values are comparing the prevalence of each antibiotic resistance gene among geographical regions. P values in boldface type represent statistically significant results.

care facilities in Japan, including the hospital in this study, to minimize transmission. These factors might explain at least in part the differences in the prevalence and clonality of ST131 between these two Asian countries. In contrast, prevalent clonal spread of ESBL-*E. coli* appears to have occurred in Nepal, where poor infection control practices and sanitation might facilitate dissemination of antimicrobial-resistant strains.

**TABLE 3** Comparison of virotypes and virulence-associated traits and genes in *Escherichia coli* ST131

Virotypes or virulence-associated trait and gene	<i>fimH</i> allele or sublineage	Total no. of isolates (n = 132)	No. of isolates (%) from:					P value <sup>d</sup>	
			Nepal (n = 54)	Japan (n = 12) <sup>a</sup>	Other Asian countries (n = 3) <sup>b</sup>	USA (n = 29) <sup>b</sup>	Europe (n = 29) <sup>b,c</sup>		Africa (n = 5) <sup>b</sup>
<b>Virotypes</b>									
A	Total	12	5 (9.3)	2 (16.7)	0	1 (3.4)	4 (13.8)	0	0.619
	H30Rx	9	5 (9.3)	1 (8.3)		1 (3.4)	2 (6.9)		
	H30R	1		1 (8.3)					
	H41	2					2 (6.9)		
B	Total	4	0	0	0	0	4 (13.8)	0	<b>0.012</b>
	H30Rx	1	0				1 (3.4)		
	H30R	1					1 (3.4)		
	H41	2					2 (6.9)		
C	Total	54	13 (24.1)	6 (50)	2 (66.7)	23 (79.3)	9 (31)	1 (20)	<b>&lt;0.001</b>
	H30Rx	33	13 (24.1)	5 (41.7)	1 (33.3)	12 (41.4)	2 (6.9)		
	H30R	14		1 (8.3)	1 (33.3)	9 (31)	2 (6.9)	1 (20)	
	H41	4				2 (6.9)	2 (6.9)		
D <sup>e</sup>	Total	9	0	0	0	0	9 (31)	0	<b>&lt;0.001</b>
	H22	9					9 (31)		
E	Total	18	10 (18.5)	3 (25)	0	2 (6.9)	1 (3.4)	2 (40)	0.09
	H30Rx	17	10 (18.5)	2 (16.7)		2 (6.9)	1 (3.4)	2 (40)	
	H30R	1		1 (8.3)					
Other	Total	35	26 (48.1)	1 (8.3)	1 (33.3)	3 (10.3)	2 (6.9)	2 (40)	<b>&lt;0.001</b>
	H30Rx	28	26 (48.1)		1 (33.3)	1 (3.4)			
	H30R	2				2 (6.9)			
	H27	2						2 (40)	
	H41	3		1 (8.3)			2 (6.9)		
<b>Virulence-associated traits and genes</b>									
<b>Adhesin</b>									
<i>papGII</i>	Total	46	35 (64.8)	3 (25)	1 (33.3)	2 (6.9)	1 (3.4)	4 (80)	<b>&lt;0.001</b>
	H30Rx	43	35 (64.8)	2 (16.7)	1 (33.3)	2 (6.9)	1 (3.4)	2 (40)	
	H30R	1		1 (8.3)					
	H27	2						2 (40)	
<i>iha</i>	Total	119	53 (98.1)	10 (83.3)	3 (100)	27 (93.1)	24 (82.8)	2 (40)	<b>0.001</b>
	H30Rx	86	53 (98.1)	8 (66.7)	2 (66.7)	16 (55.2)	6 (20.7)	1 (20)	
	H30R	16		2 (16.7)	1 (33.3)	9 (31)	3 (10.3)	1 (20)	
	H22	4				4 (13.8)			
<i>hra</i>	Total	33	11 (20.4)	3 (25)	0	2 (6.9)	8 (27.6)	1 (20)	0.085
	H30Rx	11		3 (25)		8 (27.6)	0		
	H27	1						1 (20)	
<b>Toxin</b>									
<i>hlyA</i>	Total	20	10 (18.5)	3 (25)	0	2 (6.9)	1 (3.4)	4 (80)	<b>&lt;0.001</b>
	H30Rx	7		2 (16.7)		2 (6.9)	1 (3.4)	2 (40)	
	H30R	1		1 (8.3)					
	H27	2						2 (40)	
<i>cnfI</i>	Total	19	9 (16.7)	3 (25)	0	2 (6.9)	1 (3.4)	4 (80)	<b>&lt;0.001</b>
	H30Rx	7		2 (16.7)		2 (6.9)	1 (3.4)	2 (40)	
	H30R	1		1 (8.3)					
	H27							2 (40)	
<i>sat</i>	Total	118	54 (100)	10 (83.3)	3 (100)	26 (89.7)	22 (75.9)	3 (60)	<b>0.004</b>
	H30Rx	33		8 (66.7)	2 (66.7)	15 (51.7)	6 (20.7)	2 (40)	
	H30R	16		2 (16.7)	1 (33.3)	9 (31)	3 (10.3)	1 (20)	
	H22	4					4 (13.8)		
	H41	8				2 (6.9)	6 (20.7)		
<b>Siderophore</b>									
<i>iroN</i>	Total	11	0	0	0	0	11 (37.9)	0	<b>&lt;0.001</b>
	H30Rx	1					1 (3.4)		
	H30R	1					1 (3.4)		
	H22	7					7 (24.1)		
	H41	2					2 (6.9)		

(Continued on following page)

Downloaded from <http://msphere.asm.org/> on December 26, 2017 by guest

TABLE 3 (Continued)

Virotype or virulence-associated trait and gene	<i>fimH</i> allele or sublineage	Total no. of isolates (n = 132)	No. of isolates (%) from:					P value <sup>d</sup>	
			Nepal (n = 54)	Japan (n = 12) <sup>a</sup>	Other Asian countries (n = 3) <sup>b</sup>	USA (n = 29) <sup>b</sup>	Europe (n = 29) <sup>b,c</sup>		Africa (n = 5) <sup>b</sup>
<i>fyuA</i>	Total	130	53 (98.1)	12 (100)	3 (100)	29 (100)	28 (96.6)	5 (100)	0.911
	H30Rx	87	53 (98.1)	8 (66.7)	2 (66.7)	16 (55.2)	6 (20.7)	2 (40)	
	H30R	19		3 (25)	1 (33.3)	11 (37.9)	3 (10.3)	1 (20)	
	H22	9					9 (31)		
	H27	2						2 (40)	
	H41	11		1 (8.3)		2 (6.9)	8 (27.6)		
<i>ireA</i>	Total	3	2 (3.7)	0	1 (33.3)	0	0	0	<b>0.009</b>
	H30Rx	3	2 (3.7)		1 (33.3)				
Protectins									
<i>kfiA</i>	Total	43	13 (23.6)	4 (33.3)	0	13 (44.8)	9 (31)	4 (80)	0.066
	H30Rx	28	13 (23.6)	2 (16.7)		9 (31)	2 (6.9)	2 (40)	
	H30R	8		2 (16.7)		4 (13.8)	1 (3.4)	1 (20)	
	H22	4					4 (13.8)		
	H27	1						1 (20)	
	H41	1							
<i>iss</i>	Total	9	0	0	1 (33.3)	0	8 (27.6)	0	<b>&lt;0.001</b>
	H30Rx	1			1 (33.3)				
	H30R	1					1 (3.4)		
	H22	5					5 (17.2)		
	H41	2					2 (6.9)		
Invasin									
<i>ibeA</i>	Total	9	0	0	0	0	9 (31)	0	<b>&lt;0.001</b>
	H22	9					9 (31)		
Miscellaneous									
<i>traT</i>	Total	107	47 (87)	10 (83.3)	1 (33.3)	17 (58.6)	29 (100)	3 (60)	<b>&lt;0.001</b>
	H30Rx	68	47 (87)	7 (58.3)		6 (20.7)	6 (20.7)	2 (40)	
	H30R	16		3 (25)	1 (33.3)	9 (31)	3 (10.3)		
	H22	9					9 (31)		
	H27	1						1 (20)	
	H41	10				2 (6.9)	8 (27.6)		
	H41	10				2 (6.9)	8 (27.6)		
<i>ompT</i>	Total	129	54 (100)	12 (100)	2 (66.7)	28 (96.6)	28 (96.6)	5 (100)	<b>0.01</b>
	H30Rx	87	54 (100)	8 (66.7)	1 (33.3)	16 (55.2)	6 (20.7)	2 (40)	
	H30R	18		3 (25)	1 (33.3)	10 (34.5)	3 (10.3)	1 (20)	
	H22	9					9 (31)		
	H27	2						2 (40)	
	H41	11		1 (8.3)		2 (6.9)	8 (27.6)		
	H41	11		1 (8.3)		2 (6.9)	8 (27.6)		
<i>malX</i>	Total	131	54 (100)	12 (100)	3 (100)	29 (100)	28 (96.6)	5 (100)	0.911
	H30Rx	88	54 (100)	8 (66.7)	2 (66.7)	16 (55.2)	6 (20.7)	2 (40)	
	H30R	19		3 (25)	1 (33.3)	11 (37.9)	3 (10.3)	1 (20)	
	H22	9					9 (31)		
	H27	2						2 (40)	
	H41	11		1 (8.3)		2	8 (27.6)		

<sup>a</sup>Includes one publicly available sequence of *E. coli* ST131.

<sup>b</sup>Publicly available sequence data for *E. coli* ST131.

<sup>c</sup>Three isolates from Europe were from Lebanon.

<sup>d</sup>The *P* values are comparing the prevalence of each antibiotic resistance gene among geographical regions. *P* values in boldface type represent statistically significant results.

<sup>e</sup>All isolates of virotype D were identified as D3.

In Nepal, antibiotics can be purchased in the community at general retail stores and pharmacies. According to recent reports, 80% of the drugs are purchased outside the government-supplied health system (17, 18). In addition, inappropriate prescription occurs in up to 40% of patients (17, 18).

*E. coli* ST131 isolates from the United States are distributed across the phylogeny, even those isolates that were collected in the same year. The wide diversity of population in the United States might explain in part this phylogenetic characteristic. *E. coli* ST131 isolates from Europe (including three *E. coli* ST131 isolates from Lebanon) could be roughly divided into four clusters, with one major cluster consisting mainly of

**TABLE 4** Comparison of plasmid replicon types of *Escherichia coli* ST131

Replicon type	<i>fimH</i> allele or sublineage	Total no. of isolates	No. of isolates (%) from:						<i>P</i> value <sup>d</sup>
			Nepal (n = 54)	Japan (n = 12) <sup>a</sup>	Other Asian countries (n = 3) <sup>b</sup>	USA (n = 29) <sup>b</sup>	Europe (n = 29) <sup>b,c</sup>	Africa (n = 5) <sup>b</sup>	
IncFIA	Total	84	38 (70.4)	6 (50)	2 (66.7)	25 (86.2)	10 (34.5)	3 (60)	<b>0.002</b>
	H30Rx	62	38 (70.4)	4 (33.3)	1 (33.3)	14 (48.3)	3 (10.3)	2 (40)	
	H30R	17		2 (16.7)	1 (33.3)	11 (37.9)	2 (6.9)	1 (20)	
	H41	2					2 (6.9)		
IncFIB	Total	89	40 (74.1)	8 (66.7)	1 (33.3)	14 (48.3)	23 (79.3)	3 (60)	0.09
	H30Rx	48	40 (74.1)	5 (41.7)		2 (6.9)	1 (3.4)		
	H30R	18		3 (25)	1 (33.3)	10 (34.5)	3 (10.3)	1 (20)	
	H22	9					9 (31)		
	H27	2						2 (40)	
IncFIC	Total	3	0	0	0	2 (6.9)	8 (27.6)	0	0.053
	H22	1					3 (10.3)		
	H41	2					1 (3.4)		
IncFII	Total	95	43 (79.6)	4 (33.3)	1 (33.3)	23 (79.3)	21 (72.4)	3 (60)	<b>0.017</b>
	H30Rx	60	43 (79.6)	2 (16.7)		11 (37.9)	2 (6.9)	2 (40)	
	H30R	17		2 (16.7)	1 (33.3)	10 (34.5)	3 (10.3)	1 (20)	
	H22	8					8 (27.6)		
	H41	8				2 (6.9)	6 (20.7)		
IncI1	Total	9	3 (5.6)	2 (16.7)	1 (33.3)	1 (3.4)	2 (6.9)	0	0.29
	H30Rx	5	3 (5.6)	1 (8.3)		1 (3.4)			
	H30R	2		1 (8.3)	1 (33.3)				
	H41	2					2 (6.9)		
IncFrepB	Total	40	13 (24.1)	3 (25)	0	15 (51.7)	7 (24.1)	2 (40)	0.091
	H30Rx	32	13 (24.1)	2 (16.7)		12 (41.4)	3 (10.3)	2 (40)	
	H30R	4		1 (8.3)		3 (10.3)			
	H22	4					4 (13.8)		
IncB/O	Total	1	0	0	0	1 (3.4)	0	0	0.611
	H30R	1				1 (3.4)			
IncY	Total	2	0	0	0	1 (3.4)	1 (3.4)	0	0.763
	H30Rx	1					1 (3.4)		
IncN	Total	8	0	2 (16.7)	0	2 (6.9)	4 (13.8)	0	0.092
	H30Rx	6		1 (8.3)		2 (6.9)	3 (10.3)		
	H30R	1		1 (8.3)					
	H22	1					1 (3.4)		
IncP	Total	3	0	0	0	0	1 (3.4)	2 (40)	<b>&lt;0.001</b>
	H30R	1					1 (3.4)		
	H27	2						2 (40)	
IncA/C	Total	2	0	0	0	2 (6.9)	0	0	0.205
	H30R	2				2 (6.9)			

<sup>a</sup>Includes one publicly available sequence of *E. coli* ST131.

<sup>b</sup>Publicly available sequence data for *E. coli* ST131.

<sup>c</sup>Three isolates from Europe were from Lebanon.

<sup>d</sup>The *P* values are comparing the prevalence of each antibiotic resistance gene among geographical regions. *P* values in boldface type represent statistically significant results.

*E. coli* ST131 isolates from Denmark and one cluster consisting of two *E. coli* ST131 isolates from Lebanon. *E. coli* ST131 isolates from Denmark predominantly consisted of *E. coli* ST131 from Europe (72%). Four *E. coli* ST131 isolates from Tanzania and one isolate from South Africa were included in *E. coli* ST131 from Africa. *E. coli* ST131 isolates from Africa were phylogenetically diverse. *E. coli* ST131 isolates from Asian countries other than Nepal and Japan included one isolate from South Korea, one isolate from India, and one isolate from Thailand. They did not belong to the same cluster.

There are several limitations to this study. Since ESBL-*E. coli* ST131 isolates from Nepal and Japan were collected during a relatively short period of time, epidemiologically related isolates may have been included in the analysis, and the trends across years could not be elucidated. However, as shown in Fig. 1, the distribution of ESBL-*E. coli* ST131 isolates in each region suggests that the contribution of such clonal isolates was unlikely to have been remarkable. Due to the small number of isolates from Japan,

the power of the statistical comparisons between isolates from Nepal and Japan is limited. Also, only small numbers of *E. coli* ST131 isolates from some geographical regions such as Africa could be included due to limited publicly available data. Finally, the difference in the molecular analyses, i.e., WGS and PCR, used might have caused the difference in the identification of the target genes.

In conclusion, comparative analysis of ESBL-*E. coli* ST131 genomes from Japan and Nepal and those from other geographical regions revealed distinct phylogenetic characteristics of the spread of ESBL-*E. coli* ST131 in these two geographical areas of Asia. Multiple yet distinct factors might contribute to the local spread of ESBL-*E. coli* ST131 in each region.

## MATERIALS AND METHODS

**Isolates and susceptibility testing.** All ESBL-*E. coli* isolates were serially collected from the Tribhuvan University Teaching Hospital (444 beds), Kathmandu, Nepal, between 1 February 2013 and 31 July 2013 and from the National Center for Global Health and Medicine (NCGM) (781 beds), Tokyo, Japan, between 1 October 2013 and 30 September 2014; both centers are tertiary teaching hospitals. Some of the isolates from Nepal were included in our previous study (5).

The *E. coli* strains from both Nepal and Japan were identified, and their susceptibility was tested in accordance with the Clinical and Laboratory Standards Institute (CLSI) criteria (19) by using an automated broth microdilution system (MicroScan; Siemens AG, Germany) unless otherwise stated. The MIC of fosfomycin was determined using an NC6.11J panel (Siemens AG, Germany) which contains glucose-6-phosphate, and its susceptibility status was determined as previously reported (20). ESBL production was confirmed by disc diffusion tests in accordance with the 2009 CLSI criteria (19). If multiple ESBL-*E. coli* isolates were identified from a patient during the study period, only the first isolate was included.

**Whole-genome sequencing and phylogenetic analysis.** Molecular analysis was conducted at the Department of Infectious Diseases, Research Institute, National Center for Global Health and Medicine, Tokyo, Japan. The strains were cultured overnight in lysogeny broth (LB) (Nakarai Tesque, Kyoto, Japan), and genomic DNA was purified using a DNeasy blood and tissue kit (Qiagen, Venlo, Netherlands). The genomes of the isolates were then subjected to MiSeq sequencing by using Nextera XT library kits (Illumina, Inc., San Diego, CA), according to the manufacturer's instructions. Approximately 1 million paired-end reads (301 bp × 2) were obtained from each genome and analyzed using the CLC Genomics Workbench software (CLC Bio, Aarhus, Denmark). The reads from each isolate were trimmed by screening for base quality (quality score limit of 0.05; reads that contained greater than two ambiguous nucleotides or that were less than 15 bp in length were removed) (21). The resulting sequencing data were registered with the DNA Data Bank of Japan (DDBJ) (DDBJ accession no. DRA003515). Velvet and Mummer (open source MUMmer 3.0) described previously were used for *de novo* assembly to prepare contigs and single nucleotide polymorphism (SNP) calling, respectively (21, 22).

All genome sequence data for ST131 strains available up to January 2015 were downloaded from the NCBI database ([http://www.ncbi.nlm.nih.gov/genome/genomes/167?genome\\_assembly\\_id=group161531](http://www.ncbi.nlm.nih.gov/genome/genomes/167?genome_assembly_id=group161531); accessed 26 September 2016) and included for phylogenetic analysis to determine the sequence diversity. SNP concatenations were prepared using a custom script and aligned using MAFFT (23). *E. coli* SE15 (accession no. NC\_013654.1) was used as the reference to call SNPs of the isolates after mobile elements were removed from the chromosome. The appropriate evolutionary model (transversion model plus gamma distribution) was determined using jModelTest2 (24). Maximum likelihood (ML) phylogenetic trees were estimated using PHYML 3.0 (25). Branch support for nodes was assessed using the Shimodaira and Hasegawa (SH) test implemented in PHYML.

The contigs were subjected to further analyses by using the BLAST algorithm (26) and ResFinder (27) to identify whether virulence marker genes and drug resistance genes were present in the genomes (28, 29). An identification rate of more than 97% was considered positive for each target gene. Phylotypes (30), virulence genotypes (31), *fimH* alleles and *H30R* and *H30Rx* sublineages of ST131 (10), and distribution of acquired drug resistance genes were determined. The nucleotide sequences corresponding to the ST131 multilocus sequence typing (MLST) allelic profile (*adh53*, *fumC40*, *gyrB47*, *icd13*, *mdh36*, *purA28*, and *recA29*) were downloaded from the University of Warwick (<http://mlst.warwick.ac.uk/mlst/>) and compared by BLAST algorithm to the WGS data (3, 26). Virotypes were determined based on the virulence gene scheme (13). Sequence typing of plasmid replicons was performed as described elsewhere (32, 33).

We added one *E. coli* ST131 isolate from Japan for which sequence data were available publicly ([http://www.ncbi.nlm.nih.gov/genome/genomes/167?genome\\_assembly\\_id=group161531](http://www.ncbi.nlm.nih.gov/genome/genomes/167?genome_assembly_id=group161531); accessed 26 September 2016). SE15 is a completely sequenced ST131 representative strain, which was used as a reference in the current study and a previous study as well (3).

**Statistical analysis.** All statistical analyses were performed using IBM-SPSS statistics 20 (2012). Bivariate analyses were performed using Fisher's exact test or chi-square test for categorical variables and the Mann-Whitney U test for continuous variables. All *P* values were two sided. The percentage values included in this article are the "valid percentages," which exclude the missing data.

**Accession number(s).** Sequence data were deposited in the DNA Data Bank of Japan (DDBJ) under accession no. DRA003515.

## ACKNOWLEDGMENTS

We thank Y. Sakurai for help in the preparation of the figure.

This work was supported in part by a grant in Clinical Epidemiology Research, St. Luke's International University, Tokyo, Japan (2016).

## FUNDING INFORMATION

This work was funded in part by St. Luke's International University, Tokyo, Japan.

## REFERENCES

1. **World Health Organization.** 2014. Antimicrobial resistance: global report on surveillance 2014. World Health Organization, Geneva, Switzerland. <http://www.who.int/drugresistance/documents/surveillance-report/en/>.
2. **Rogers BA, Sidjabat HE, Paterson DL.** 2011. *Escherichia coli* O25b-ST131: a pandemic, multiresistant, community-associated strain. *J Antimicrob Chemother* **66**:1–14. <http://dx.doi.org/10.1093/jac/dkq415>.
3. **Petty NK, Ben Zakour NL, Stanton-Cook M, Skippington E, Totsika M, Forde BM, Phan MD, Gomes Moriel D, Peters KM, Davies M, Rogers BA, Dougan G, Rodriguez-Baño J, Pascual A, Pitout JD, Upton M, Paterson DL, Walsh TR, Schembri MA, Beatson SA.** 2014. Global dissemination of a multidrug resistant *Escherichia coli* clone. *Proc Natl Acad Sci USA* **111**:5694–5699. <http://dx.doi.org/10.1073/pnas.1322678111>.
4. **Blanco J, Mora A, Mamani R, López C, Blanco M, Dahbi G, Herrera A, Marzoa J, Fernández V, de la Cruz F, Martínez-Martínez L, Alonso MP, Nicolas-Chanoine MH, Johnson JR, Johnston B, López-Cerero L, Pascual A, Rodríguez-Baño J, Spanish Group for Nosocomial Infections (GEIH).** 2013. Four main virotypes among extended-spectrum-beta-lactamase-producing isolates of *Escherichia coli* O25b:H4-B2-ST131: bacterial, epidemiological, and clinical characteristics. *J Clin Microbiol* **51**:3358–3367. <http://dx.doi.org/10.1128/JCM.01555-13>.
5. **Sherchan JB, Hayakawa K, Miyoshi-Akiyama T, Ohmagari N, Kirikae T, Nagamatsu M, Tojo M, Ohara H, Sherchand JB, Tandukar S.** 2015. Clinical epidemiology and molecular analysis of extended-spectrum-beta-lactamase-producing *Escherichia coli* in Nepal: characteristics of sequence types 131 and 648. *Antimicrob Agents Chemother* **59**:3424–3432. <http://dx.doi.org/10.1128/AAC.00270-15>.
6. **Pitout JD, Campbell L, Church DL, Greason DB, Laupland KB.** 2009. Molecular characteristics of travel-related extended-spectrum-beta-lactamase-producing *Escherichia coli* isolates from the Calgary Health Region. *Antimicrob Agents Chemother* **53**:2539–2543. <http://dx.doi.org/10.1128/AAC.00061-09>.
7. **Suzuki S, Shibata N, Yamane K, Wachino J, Ito K, Arakawa Y.** 2009. Change in the prevalence of extended-spectrum-beta-lactamase-producing *Escherichia coli* in Japan by clonal spread. *J Antimicrob Chemother* **63**:72–79. <http://dx.doi.org/10.1093/jac/dkn463>.
8. **Matsumura Y, Yamamoto M, Nagao M, Hotta G, Matsushima A, Ito Y, Takakura S, Ichiyama S, Kyoto-Shiga Clinical Microbiology Study Group.** 2012. Emergence and spread of B2-ST131-O25b, B2-ST131-O16 and D-ST405 clonal groups among extended-spectrum-beta-lactamase-producing *Escherichia coli* in Japan. *J Antimicrob Chemother* **67**:2612–2620. <http://dx.doi.org/10.1093/jac/dks278>.
9. **Matsumura Y, Johnson JR, Yamamoto M, Nagao M, Tanaka M, Takakura S, Ichiyama S, Kyoto-Shiga Clinical Microbiology Study Group.** 2015. CTX-M-27- and CTX-M-14-producing, ciprofloxacin-resistant *Escherichia coli* of the H30 subclonal group within ST131 drive a Japanese regional ESBL epidemic. *J Antimicrob Chemother* **70**:1639–1649. <http://dx.doi.org/10.1093/jac/dkv017>.
10. **Price LB, Johnson JR, Aziz M, Clabots C, Johnston B, Tchesnokova V, Nordstrom L, Billig M, Chattopadhyay S, Stegger M, Andersen PS, Pearson T, Riddell K, Rogers P, Scholes D, Kahl B, Keim P, Sokurenko EV.** 2013. The epidemic of extended-spectrum-beta-lactamase-producing *Escherichia coli* ST131 is driven by a single highly pathogenic subclone, H30-Rx. *mBio* **4**:e00377-13. <http://dx.doi.org/10.1128/mBio.00377-13>.
11. **Kim SY, Park YJ, Johnson JR, Yu JK, Kim YK, Kim YS.** 2016. Prevalence and characteristics of *Escherichia coli* sequence type 131 and its H30 and H30Rx subclones: a multicenter study from Korea. *Diagn Microbiol Infect Dis* **84**:97–101. <http://dx.doi.org/10.1016/j.diagmicrobio.2015.10.016>.
12. **Peirano G, van der Bij AK, Freeman JL, Poirer L, Nordmann P, Costello M, Tchesnokova VL, Pitout JD.** 2014. Characteristics of *Escherichia coli* sequence type 131 isolates that produce extended-spectrum beta-lactamases: global distribution of the H30-Rx sublineage. *Antimicrob Agents Chemother* **58**:3762–3767. <http://dx.doi.org/10.1128/AAC.02428-14>.
13. **Mora A, Dahbi G, López C, Mamani R, Marzoa J, Dion S, Picard B, Blanco M, Alonso MP, Denamur E, Blanco J.** 2014. Virulence patterns in a murine sepsis model of ST131 *Escherichia coli* clinical isolates belonging to serotypes O25b:H4 and O16:H5 are associated to specific virotypes. *PLoS One* **9**:e87025. <http://dx.doi.org/10.1371/journal.pone.0087025>.
14. **Marcadé G, Deschamps C, Boyd A, Gautier V, Picard B, Branger C, Denamur E, Arlet G.** 2009. Replicon typing of plasmids in *Escherichia coli* producing extended-spectrum beta-lactamases. *J Antimicrob Chemother* **63**:67–71. <http://dx.doi.org/10.1093/jac/dkn428>.
15. **Mathers AJ, Peirano G, Pitout JD.** 2015. The role of epidemic resistance plasmids and international high-risk clones in the spread of multidrug-resistant *Enterobacteriaceae*. *Clin Microbiol Rev* **28**:565–591. <http://dx.doi.org/10.1128/CMR.00116-14>.
16. **Phan MD, Forde BM, Peters KM, Sarkar S, Hancock S, Stanton-Cook M, Ben Zakour NL, Upton M, Beatson SA, Schembri MA.** 2015. Molecular characterization of a multidrug resistance IncF plasmid from the globally disseminated *Escherichia coli* ST131 clone. *PLoS One* **10**:e0122369. <http://dx.doi.org/10.1371/journal.pone.0122369>.
17. **Alliance for the Prudent Use of Antibiotics (APUA) Nepal.** 2015. APUA Nepal. Alliance for the Prudent Use of Antibiotics, Boston, MA. [http://www.tufts.edu/med/apua/intl\\_chapters/nepal.shtml](http://www.tufts.edu/med/apua/intl_chapters/nepal.shtml). Accessed 20 September 2016.
18. **GARP-Nepal National Working Group.** 2015. Situation analysis and recommendations. Antibiotic use and resistance in Nepal. Global Antibiotic Resistance Partnership (GARP), Center for Disease Dynamics, Economics & Policy, Washington, DC. [http://cddep.org/publications/garp\\_nepal\\_situation\\_analysis#sthash.DKyQe07e.dpbs](http://cddep.org/publications/garp_nepal_situation_analysis#sthash.DKyQe07e.dpbs). Accessed 20 September 2016.
19. **Clinical and Laboratory Standards Institute.** 2009. Performance standards for antimicrobial susceptibility testing; nineteenth informational supplement. Approved standard M100-S19. Clinical and Laboratory Standards Institute, Wayne, PA.
20. **Kresken M, Pfeifer Y, Hafner D, Wresch R, Körber-Irrgang B, Working Party 'Antimicrobial Resistance' of the Paul-Ehrlich-Society for Chemotherapy.** 2014. Occurrence of multidrug resistance to oral antibiotics among *Escherichia coli* urine isolates from outpatient departments in Germany: extended-spectrum beta-lactamases and the role of fosfomycin. *Int J Antimicrob Agents* **44**:295–300. <http://dx.doi.org/10.1016/j.ijantimicag.2014.05.020>.
21. **Zerbino DR, Birney E.** 2008. Velvet: algorithms for de novo short read assembly using de Bruijn graphs. *Genome Res* **18**:821–829. <http://dx.doi.org/10.1101/gr.074492.107>.
22. **Kurtz S, Phillippy A, Delcher AL, Smoot M, Shumway M, Antonescu C, Salzberg SL.** 2004. Versatile and open software for comparing large genomes. *Genome Biol* **5**:R12. <http://dx.doi.org/10.1186/gb-2004-5-2-r12>.
23. **Katoh K, Standley DM.** 2013. MAFFT multiple sequence alignment software version 7: improvements in performance and usability. *Mol Biol Evol* **30**:772–780. <http://dx.doi.org/10.1093/molbev/mst010>.
24. **Darriba D, Taboada GL, Doallo R, Posada D.** 2012. jModelTest 2: more models, new heuristics and parallel computing. *Nat Methods* **9**:772. <http://dx.doi.org/10.1038/nmeth.2109>.
25. **Guindon S, Dufayard JF, Lefort V, Anisimova M, Hordijk W, Gascuel O.** 2010. New algorithms and methods to estimate maximum-likelihood phylogenies: assessing the performance of PhyML 3.0. *Syst Biol* **59**:307–321. <http://dx.doi.org/10.1093/sysbio/syq010>.

26. **Camacho C, Coulouris G, Avagyan V, Ma N, Papadopoulos J, Bealer K, Madden TL.** 2009. BLAST+: architecture and applications. *BMC Bioinformatics* **10**:421. <http://dx.doi.org/10.1186/1471-2105-10-421>.
27. **Zankari E, Hasman H, Cosentino S, Vestergaard M, Rasmussen S, Lund O, Aarestrup FM, Larsen MV.** 2012. Identification of acquired antimicrobial resistance genes. *J Antimicrob Chemother* **67**:2640–2644. <http://dx.doi.org/10.1093/jac/dks261>.
28. **Johnson JR, Gajewski A, Lesse AJ, Russo TA.** 2003. Extraintestinal pathogenic *Escherichia coli* as a cause of invasive nonurinary infections. *J Clin Microbiol* **41**:5798–5802. <http://dx.doi.org/10.1128/JCM.41.12.5798-5802.2003>.
29. **Johnson JR, Johnston B, Clabots CR, Kuskowski MA, Roberts E, DeRoy C.** 2008. Virulence genotypes and phylogenetic background of *Escherichia coli* serogroup O6 isolates from humans, dogs, and cats. *J Clin Microbiol* **46**:417–422. <http://dx.doi.org/10.1128/JCM.00674-07>.
30. **Clermont O, Christenson JK, Denamur E, Gordon DM.** 2013. The Clermont *Escherichia coli* phylo-typing method revisited: improvement of specificity and detection of new phylo-groups. *Environ Microbiol Rep* **5**:58–65. <http://dx.doi.org/10.1111/1758-2229.12019>.
31. **Johnson JR, Menard M, Johnston B, Kuskowski MA, Nichol K, Zhanel GG.** 2009. Epidemic clonal groups of *Escherichia coli* as a cause of antimicrobial-resistant urinary tract infections in Canada, 2002 to 2004. *Antimicrob Agents Chemother* **53**:2733–2739. <http://dx.doi.org/10.1128/AAC.00297-09>.
32. **Johnson TJ, Wannemuehler YM, Johnson SJ, Logue CM, White DG, Doetkott C, Nolan LK.** 2007. Plasmid replicon typing of commensal and pathogenic *Escherichia coli* isolates. *Appl Environ Microbiol* **73**:1976–1983. <http://dx.doi.org/10.1128/AEM.02171-06>.
33. **Villa L, García-Fernández A, Fortini D, Carattoli A.** 2010. Replicon sequence typing of IncF plasmids carrying virulence and resistance determinants. *J Antimicrob Chemother* **65**:2518–2529. <http://dx.doi.org/10.1093/jac/dkq347>.



AUTHOR CORRECTION



## Correction for Miyoshi-Akiyama et al., “Comparative Genome Analysis of Extended-Spectrum- $\beta$ -Lactamase- Producing *Escherichia coli* Sequence Type 131 Strains from Nepal and Japan”

Tohru Miyoshi-Akiyama,<sup>a</sup> Jatan Bahadur Sherchan,<sup>b</sup> Yohei Doi,<sup>c</sup>  
Maki Nagamatsu,<sup>d,e</sup> Jeevan B. Sherchand,<sup>f</sup> Sarmila Tandukar,<sup>f</sup> Norio Ohmagari,<sup>d</sup>  
Teruo Kirikae,<sup>e</sup> Hiroshi Ohara,<sup>g</sup> Kayoko Hayakawa<sup>d</sup>

Pathogenic Microbe Laboratory, Research Institute, National Center for Global Health and Medicine, Tokyo, Japan<sup>a</sup>; Department of Clinical Microbiology, Kathmandu University School of Medical Sciences, Dhulikhel, Nepal<sup>b</sup>; Division of Infectious Diseases, University of Pittsburgh School of Medicine, Pittsburgh, Pennsylvania, USA<sup>c</sup>; Disease Control and Prevention Center, National Center for Global Health and Medicine, Tokyo, Japan<sup>d</sup>; Department of Infectious Diseases, Research Institute, National Center for Global Health and Medicine, Tokyo, Japan<sup>e</sup>; Public Health Research Laboratory, Institute of Medicine, Tribhuvan University Teaching Hospital, Kathmandu, Nepal<sup>f</sup>; Department of International Medical Cooperation, National Center for Global Health and Medicine, Tokyo, Japan<sup>g</sup>

Volume 1, no. 5, e00289-16, 2016, <https://doi.org/10.1128/mSphere.00289-16>. Due to the classification definitions that we used for our work, six isolates were misclassified for the *fimH* allele or sublineage in our paper. The revised *fimH* alleles or sublineages are as follows: HVH186 (H30Rx), J069 (H30Rx), N439/N1027/N1471 (H30R [non-Rx]), and N1449 (H41). A revised figure and revised tables are available from the authors upon request. (We are extremely grateful to Yasufumi Matsumura, Kyoto University Graduate School of Medicine, Japan, for his tremendous help on molecular analysis.)

**Published** 24 May 2017

**Citation** Miyoshi-Akiyama T, Sherchan JB, Doi Y, Nagamatsu M, Sherchand JB, Tandukar S, Ohmagari N, Kirikae T, Ohara H, Hayakawa K. 2017. Correction for Miyoshi-Akiyama et al., “Comparative genome analysis of extended-spectrum- $\beta$ -lactamase-producing *Escherichia coli* sequence type 131 strains from Nepal and Japan.” *mSphere* 2:e00136-17. <https://doi.org/10.1128/mSphere.00136-17>.

**Copyright** © 2017 Miyoshi-Akiyama et al. This is an open-access article distributed under the terms of the Creative Commons Attribution 4.0 International license.

Address correspondence to Kayoko Hayakawa, [kayokohayakawa@gmail.com](mailto:kayokohayakawa@gmail.com).



AMERICAN  
SOCIETY FOR  
MICROBIOLOGYAntimicrobial Agents  
and Chemotherapy®

MECHANISMS OF RESISTANCE



## PER-8, a Novel Extended-Spectrum $\beta$ -Lactamase PER Variant, from an *Acinetobacter baumannii* Clinical Isolate in Nepal

Tatsuya Tada,<sup>a</sup> Shovita Shrestha,<sup>b</sup> Kayo Shimada,<sup>a</sup> Hiroshi Ohara,<sup>c</sup>  
Jeevan B. Sherchand,<sup>b</sup> Bharat M. Pokhrel,<sup>d</sup> Teruo Kirikae<sup>a</sup>

Department of Infectious Diseases, Research Institute, National Center for Global Health and Medicine, Tokyo, Japan<sup>a</sup>; Department of Medical Microbiology, Tribhuvan University, Maharajgunj, Kathmandu, Nepal<sup>b</sup>; Department of International Medical-Cooperation, National Center for Global Health and Medicine, Tokyo, Japan<sup>c</sup>; Department of Microbiology, Institute of Medicine, Tribhuvan University, Maharajgunj, Kathmandu, Nepal<sup>d</sup>

**ABSTRACT** A novel PER-type extended-spectrum  $\beta$ -lactamase, PER-8, was identified in an *Acinetobacter baumannii* clinical isolate obtained in Nepal. The amino acid sequence of PER-8 has a substitution at position 39 (Gly to Glu) compared with that of PER-7. The  $k_{cat}/K_m$  ratio of PER-8 for aztreonam was lower than that of PER-7, while the  $k_{cat}/K_m$  ratio of PER-8 for imipenem was higher than that of PER-7. The genomic environment surrounding  $bla_{PER-8}$  was *intl1 bla\_{PSE-1} qacEDI sll ISCR1-bla\_{PER-8} gts sll orfX* on a 100-kb plasmid.

**KEYWORDS** *Acinetobacter baumannii*, PER-type ESBLs, plasmid-mediated resistance

The class A extended-spectrum  $\beta$ -lactamases (ESBLs) confer resistance to expanded-spectrum cephalosporins and are inhibited *in vitro* by clavulanic acid and tazobactam (1). Resistance to broad-spectrum cephalosporins in *Acinetobacter baumannii* mostly results from overexpression of the natural AmpC-type enzyme or from acquisition of ESBLs. To date, the following 5 types of ESBL genes have been reported in *A. baumannii*:  $bla_{PER}$  (2),  $bla_{GES}$  (3),  $bla_{VEB}$  (4),  $bla_{TEM}$  (5), and  $bla_{CTX-M}$  (6). The  $bla_{PER-1}$  gene was first found in a *Pseudomonas aeruginosa* isolate (7). Since then, it has been reported worldwide in *Enterobacteriaceae* (8–11) and *A. baumannii* (2, 4). Until now, 7 types of PER variants have been reported in clinical isolates of *Enterobacteriaceae* (12–16) and *A. baumannii* (17) in various countries. The phylogenetic tree based on amino acid sequences (Clustal W2) revealed two clusters in PER-type variants, one containing PER-1, PER-3, PER-4, PER-5, and PER-7 and the other containing PER-2 and PER-6.

Multidrug-resistant *A. baumannii* IOMTU442 and IOMTU448 were isolated from samples of wound swabs from hospitalized patients at a university hospital in 2013 in Nepal. The isolates were identified phenotypically, and species identification was confirmed by comparing sequences of 16S rRNA, *gyrB*, and  $bla_{OXA-51-like}$  genes. *Escherichia coli* DH5 $\alpha$  (TaKaRa Bio, Shiga, Japan) and *E. coli* BL21-CodonPlus(DE3)-RIP (Agilent Technologies, Santa Clara, CA) were used as hosts for recombinant plasmids and expression of  $bla_{PER}$  genes, respectively.

MICs were determined using the broth microdilution method as recommended by CLSI (M100-S23). Whole genomes of IOMTU442 and IOMTU448 were extracted with DNeasy blood and tissue kits (Qiagen, Tokyo, Japan) and sequenced by MiSeq (Illumina, San Diego, CA). Multilocus sequence typing (MLST) was performed as described by the protocols of the Institut Pasteur MLST ([http://pubmlst.org/perl/bigsgdb/bigsgdb.pl?db=pubmlst\\_abaumannii\\_pasteur\\_seqdef](http://pubmlst.org/perl/bigsgdb/bigsgdb.pl?db=pubmlst_abaumannii_pasteur_seqdef)) databases.

Received 1 November 2016 Returned for modification 20 November 2016 Accepted 17 December 2016

Accepted manuscript posted online 28 December 2016

**Citation** Tada T, Shrestha S, Shimada K, Ohara H, Sherchand JB, Pokhrel BM, Kirikae T. 2017. PER-8, a novel extended-spectrum  $\beta$ -lactamase PER variant, from an *Acinetobacter baumannii* clinical isolate in Nepal. *Antimicrob Agents Chemother* 61:e02300-16. <https://doi.org/10.1128/AAC.02300-16>.

**Copyright** © 2017 American Society for Microbiology. All Rights Reserved.

Address correspondence to Teruo Kirikae, [tkirikae@ri.ncgm.go.jp](mailto:tkirikae@ri.ncgm.go.jp).

T.T. and S.S. contributed equally to this article.

Downloaded from <http://aac.asm.org/> on December 25, 2017 by Kohnodai Hospital, National Center for Global Health and Medicine

**TABLE 1** MICs of various  $\beta$ -lactams for *A. baumannii* strains IOMTU442 and IOMTU448 and *E. coli* DH5 $\alpha$  transformed with PER-7- or PER-8-encoding plasmids

Antibiotic(s) <sup>a</sup>	MIC (mg/liter)				
	IOMTU442	IOMTU448	pHSG398/PER-7	pHSG398/PER-8	pHSG398
Amikacin	>1,024	8	ND <sup>b</sup>	ND	ND
Ampicillin	>1,024	>1,024	32	16	2
Ampicillin-sulbactam	64	64	2	2	2
Arbekacin	>1,024	2	ND	ND	ND
Aztreonam	>1,024	>1,024	8	4	$\leq$ 0.063
Cefepime	512	512	0.125	0.25	$\leq$ 0.063
Cefmetazole	256	>1,024	1	1	1
Cefotaxime	512	>1,024	16	8	$\leq$ 0.063
Cefoxitin	512	>1,024	4	4	4
Cefpirome	256	256	$\leq$ 0.063	$\leq$ 0.063	$\leq$ 0.063
Ceftazidime	>1,024	512	32	64	0.5
Cephadrine	>1,024	>1,024	128	128	16
Ciprofloxacin	32	32	ND	ND	ND
Colistin	0.25	0.5	ND	ND	ND
Fosfomycin	128	256	ND	ND	ND
Gentamicin	>1,024	>1,024	ND	ND	ND
Imipenem	2	8	0.125	0.125	$\leq$ 0.063
Kanamycin	>1,024	>1,024	ND	ND	ND
Levofloxacin	32	8	ND	ND	ND
Meropenem	1	16	$\leq$ 0.063	$\leq$ 0.063	$\leq$ 0.063
Moxalactam	128	128	$\leq$ 0.063	$\leq$ 0.063	$\leq$ 0.063
Penicillin G	>1,024	>1,024	64	64	32
Piperacillin	>1,024	512	4	4	2
Piperacillin-tazobactam	64	256	2	2	2
Tigecycline	0.25	0.5	ND	ND	ND

<sup>a</sup>The ratio of ampicillin to sulbactam was 2:1. The ratio of piperacillin to tazobactam was 4:1.

<sup>b</sup>ND, not determined.

The *bla*<sub>PER-7</sub> and *bla*<sub>PER-8</sub> were cloned into the corresponding sites of the pHSG398 vector plasmid (TaKaRa, Shiga, Japan) using the primer set EcoRI-PER-F (5'-GGGAATT CATGGAATTGCCAATATTATG-3') and PstI-PER-R (5'-AACTGCAGTCAGCGCAGCTTGTCG GCCAT-3'). *E. coli* DH5 $\alpha$  was transformed with pHSG398-PERs, and the transformants were selected on chloramphenicol-containing plates (30  $\mu$ g/ml).

The open reading frames of PER-7 and PER-8, without signal peptide regions, were cloned into the pET28a expression vector (Novagen, Inc., Madison, WI, USA) using the primer set BamHI-TEV-PER-F (5'-ATGGATCCGAAAACCTGTATTCCAAAGGCCAGCAAATGG AACTGGCGAC-3') and XhoI-PER-R (5'-ATCTCGAGTCAGCGCAGCTTGTCGGCCATG-3'). The plasmids were used to transform *E. coli* BL21-CodonPlus(DE3)-RIP (Agilent Technologies, Santa Clara, CA, USA). Recombinant PERs were purified, and initial hydrolysis rates were determined as previously described (18).

To determine the size of the plasmid harboring *bla*<sub>PER-8</sub> plasmid DNA in iOMTU442 was extracted and digested with S1 nuclease. Pulsed-field gel electrophoresis (PFGE) and Southern hybridization were performed. A probe for *bla*<sub>PER</sub> from IOMTU442 was amplified by PCR using the EcoRI-PER-F and PstI-PER-R primer set. A DNA plug of IOMTU448, digested with I-CeuI, was prepared, separated by pulsed-field gel electrophoresis, and subjected to Southern hybridization using 16S rRNA and *bla*<sub>PER-7</sub> probes. Signal was detected using digoxigenin (DIG) High Prime DNA labeling and detection starter kit II (Roche Applied Science, Indianapolis, IN, USA).

IOMTU442 had *bla*<sub>OXA-70</sub>, *bla*<sub>PSE-11</sub>, and a novel *bla*<sub>PER</sub> variant, *bla*<sub>PER-8</sub>. IOMTU448 had *bla*<sub>OXA-23</sub>, *bla*<sub>OXA-371</sub>, *bla*<sub>OXA-420</sub> (*bla*<sub>OXA-58-like</sub>), and *bla*<sub>PER-7</sub>. The *bla*<sub>OXA-371</sub> gene in IOMTU 448 was grouped with the *bla*<sub>OXA-69</sub>-type genes, whereas the *bla*<sub>OXA-70</sub> gene in IOMTU442 was not grouped with the *bla*<sub>OXA-66</sub>-type genes, the *bla*<sub>OXA-69</sub>-type genes, or the *bla*<sub>OXA-71</sub>-type genes. Neither *bla*<sub>OXA-70</sub> nor *bla*<sub>OXA-371</sub> was flanked by *ISAba1*. The MICs for *A. baumannii* IOMTU442 and IOMTU448 are shown in Table 1. IOMTU442 and IOMTU448 were found to belong to ST103 and ST623, respectively. *A. baumannii* isolates belonging to ST103 have been found in Egypt (19) and Portugal (20), and ST623

**TABLE 2** Kinetic parameters of the PER-7 and PER-8 enzymes in hydrolyzing  $\beta$ -lactams<sup>a</sup>

$\beta$ -Lactam	PER-7			PER-8		
	$K_m$ ( $\mu$ M) <sup>b</sup>	$k_{cat}$ ( $s^{-1}$ ) <sup>b</sup>	$k_{cat}/K_m$ ( $\mu$ M <sup>-1</sup> s <sup>-1</sup> )	$K_m$ ( $\mu$ M) <sup>b</sup>	$k_{cat}$ ( $s^{-1}$ ) <sup>b</sup>	$k_{cat}/K_m$ ( $\mu$ M <sup>-1</sup> s <sup>-1</sup> )
Ampicillin	13 $\pm$ 4	52 $\pm$ 2	4.4	19 $\pm$ 3	54 $\pm$ 1	2.9
Penicillin G	13.7 $\pm$ 2.8	16.0 $\pm$ 0.2	1.2	13.7 $\pm$ 3.1	16.4 $\pm$ 0.3	1.2
Piperacillin	12.6 $\pm$ 3.6	0.60 $\pm$ 0.02	0.051	8.6 $\pm$ 1.8	0.65 $\pm$ 0.03	0.076
Cefepime	81 $\pm$ 7	10.2 $\pm$ 0.3	0.13	110 $\pm$ 16	12 $\pm$ 1	0.11
Cefmetazole	NH <sup>c</sup>	NH	NH	NH	NH	NH
Cefotaxime	138 $\pm$ 63	84 $\pm$ 20	0.65	114 $\pm$ 17	70 $\pm$ 4	0.62
Cefoxitin	NH	NH	NH	NH	NH	NH
Ceftazidime	258 $\pm$ 22	33 $\pm$ 2	0.13	212 $\pm$ 26	31 $\pm$ 2	0.15
Cephadrine	54 $\pm$ 5	62 $\pm$ 2	1.2	48 $\pm$ 8	66 $\pm$ 2	1.4
Moxalactam	NH	NH	NH	NH	NH	NH
Aztreonam	17 $\pm$ 3	8.8 $\pm$ 0.2	0.54	14 $\pm$ 2	8.8 $\pm$ 0.2	0.64
Imipenem	172 $\pm$ 33	0.13 $\pm$ 0.01	0.00076	101 $\pm$ 10	0.16 $\pm$ 0.01	0.0016
Meropenem	28 $\pm$ 8	0.13 $\pm$ 0.01	0.0051	32 $\pm$ 3	0.17 $\pm$ 0.01	0.0053

<sup>a</sup>The proteins were initially modified by the use of a His tag, which was removed after purification.

<sup>b</sup> $K_m$  and  $k_{cat}$  values represent the means  $\pm$  standard deviations of results of 3 independent experiments.

<sup>c</sup>NH, no hydrolysis was detected under conditions with substrate concentrations up to 1 mM and enzyme concentrations up to 700 nM.

belonged to CC1, which is known as international clone I, disseminated worldwide. The sequence of  $bla_{PER-8}$  showed a nucleotide substitution compared with  $bla_{PER-7}$ . Similarly, analysis of their predicted amino acid sequences revealed that PER-8 had a substitution (Gly39Glu) compared with PER-7; therefore, PER-7 was used as a control for PER-8. The nucleotide sequences of  $bla_{PER-8}$  and its flanking region have been deposited in GenBank under accession number AB985401.

Compared with *E. coli* DH5 $\alpha$  harboring a pHSG398 control vector, DH5 $\alpha$  harboring  $bla_{PER-7}$  or  $bla_{PER-8}$  showed significantly increased MICs of all penicillins and cephalosporins tested, except cefmetazole, ceftiofime, cefoxitin, and piperacillin, as well as slightly increased MICs of imipenem (Table 1). DH5 $\alpha$  harboring  $bla_{PER-7}$  and  $bla_{PER-8}$  had similar MICs of  $\beta$ -lactams (Table 1). Recombinant PER-7 and PER-8 hydrolyzed all  $\beta$ -lactams tested, except for cefmetazole, cefoxitin, and moxalactam (Table 2). PER-7 and PER-8 also hydrolyzed imipenem and meropenem, although their  $k_{cat}/K_m$  ratios against these substrates were quite low. The kinetic profiles of PER-8 against the  $\beta$ -lactams tested, except for imipenem, were similar to those of PER-7. The  $k_{cat}/K_m$  ratios of PER-8 were 2-fold higher for imipenem than those of PER-7 (Table 2).

PFGE analysis showed that  $bla_{PER-7}$  in IOMTU448 was located on the chromosome, whereas  $bla_{PER-8}$  in IOMTU442 was located on a 100-kb plasmid whose replicon type was classified into the GR12 type of *Acinetobacter* plasmids (21). The genomic environments surrounding  $bla_{PER-7}$  in IOMTU448 and  $bla_{PER-8}$  in IOMTU442 are shown in Fig. 1. The genomic environments surrounding  $bla_{PER-7}$  (nucleotide [nt] 1162 to nt 8196; GenBank accession no. LC020101) showed 99.4% nucleotide sequence identity with the region from nt 2172 to nt 9204 of the plasmid of *P. aeruginosa* RJ248 producing PER-1 in China (GenBank accession no. KU133340). The genomic environment surrounding  $bla_{PER-8}$  (from nt 1994 to nt 8195; GenBank accession no. AB985401) showed more than 99.9% nucleotide sequence identity with the region from nt 3083 to nt 9284 of the plasmid from *A. baumannii* A068 producing PER-7 in Sweden (GenBank accession no. KT317086).  $bla_{PER-7}$  and  $bla_{PER-8}$  were both located downstream of *ISCR1* and had identical genetic structures for the sequence between *qacEDI* and *orfX* (*orfX* is a gene encoding a putative ABC transporter ATP-binding protein) in their respective plasmids (Fig. 1). In our previous study, we reported PER-7-producing *A. baumannii* IOMTU433 in 2015 in Nepal (22). The structures upstream of the 3' coding sequence (CS) in IOMTU442 and IOMTU448 completely differed from the corresponding regions of a plasmid (pIOMTU433) in *A. baumannii* IOMTU433 (22) (Fig. 1).

*A. baumannii* harboring  $bla_{PER}$  genes, including  $bla_{PER-7}$  and  $bla_{PER-8}$ , mediated by plasmids or chromosomes may be spreading in medical settings in Nepal, because our previous study showed that 49.2% of *A. baumannii* clinical isolates in Nepal harbored  $bla_{PER}$  genes, including  $bla_{PER-7}$  and  $bla_{PER-8}$  (22). The  $bla_{PER-7}$  gene was first identified

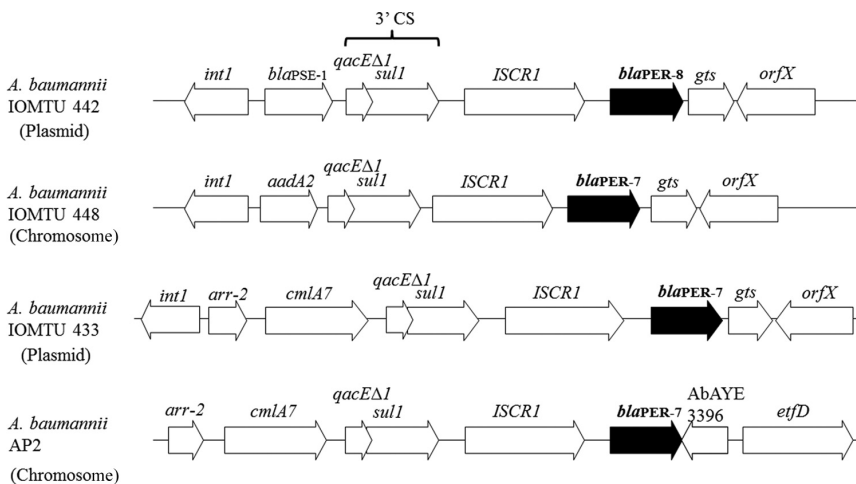

**FIG 1** Genetic environments surrounding *bla*<sub>PER</sub> genes in *A. baumannii* IOMTU442 (GenBank accession no. AB985401), IOMTU448 (GenBank accession no. LC020101), IOMTU433 (GenBank accession no. AP014650) (22), and AP2 (GenBank accession no. HQ713678) (17). The *bla*<sub>PER-7</sub> gene in *A. baumannii* AP2 was located on the chromosome, whereas the *bla*<sub>PER-7</sub> gene in *A. baumannii* IOMTU433 and the *bla*<sub>PER-8</sub> gene in *A. baumannii* IOMTU442 were located on plasmids.

in *A. baumannii* AP2 (GenBank accession no. HQ713678) in France, and the gene was located on the chromosome (17). As shown in Fig. 1, the genetic structures surrounding *bla*<sub>PER</sub> genes in IOMTU442 and IOMTU448 differ from that in AP2 because both IOMTU442 and IOMTU448 harbor *int1* in the region upstream of *bla*<sub>PER-7</sub> and *bla*<sub>PER-8</sub>, respectively, but AP2 does not. The upstream region of *bla*<sub>PER-7</sub> in *A. baumannii* AP2, *arr-2 cmlA7 qacED1 sull ISCR1*, had a structure identical to that in pIOMTU433 in *A. baumannii* IOMTU433 discovered in Nepal. The data from our present study suggest that PER-producing *A. baumannii* in Nepal probably has at least two types of genetic structures surrounding *bla*<sub>PER</sub> genes.

The insertion element *ISCR1* in the upstream region of *bla*<sub>PER</sub> genes appears to be involved in the acquisition of *bla*<sub>PER</sub> genes in *A. baumannii* in Nepal. The structure that includes 3' CS-*ISCR1* is commonly associated with the recent emergence of drug-resistant pathogens, including *E. coli*, *Klebsiella pneumoniae*, *A. baumannii*, and *P. aeruginosa*, which are linked to the drug resistance genes encoding not only metallo- $\beta$ -lactamases but also 16S rRNA methylases (23). The *ISCR1* may be associated with the genetic diversity of a  $\beta$ -lactamase-resistant factor in *A. baumannii* (24).

The *bla*<sub>OXA-70</sub> gene in IOMTU442 was first identified in *A. baumannii* clinical isolates in Hong Kong (25), whereas the *bla*<sub>OXA-371</sub> gene in IOMTU448 was first identified in *A. baumannii* clinical isolates in 2014 in Nepal (22). To date, *bla*<sub>OXA-70</sub> harboring *A. baumannii* was reported in 2014 in Canada (26). The *bla*<sub>OXA-70</sub> gene had 11, 17, and 17 nucleotide substitutions compared with *bla*<sub>OXA-71</sub>, *bla*<sub>OXA-66</sub>, and *bla*<sub>OXA-69</sub>, respectively. The *bla*<sub>OXA-371</sub> gene had only one nucleotide substitution compared with *bla*<sub>OXA-69</sub>.

In conclusion, this is the first report of *A. baumannii* isolates producing PER-7 and PER-8 in Nepal. The results of the present study indicate that plasmid- or chromosome-mediated PER-producing *A. baumannii* strains will spread in medical settings in Nepal.

**Accession number(s).** The nucleotide sequences for *bla*<sub>PER-8</sub> and its flanking region in *A. baumannii* IOMTU442 and for *bla*<sub>PER-7</sub> and its flanking region in *A. baumannii* IOMTU448 have been deposited in the GenBank database under accession numbers AB985401 and LC020101, respectively.

#### ACKNOWLEDGMENTS

This study was approved by the Institutional Review Board of the Institute of Medicine, Tribhuvan University (reference 6-11-E), and the Biosafety Committee, National Center for Global Health and Medicine (approval no. 26-M-023 and 26-D-088).

The research was supported by a grant of the Research Program on Emerging and Re-emerging Infectious Diseases from Japan Agency for Medical Research and Development (AMED), a grant (27-A-1102) from International Health Cooperation Research, and JSPS KAKENHI grant number 16K19133.

## REFERENCES

- Potron A, Poirel L, Nordmann P. 2015. Emerging broad-spectrum resistance in *Pseudomonas aeruginosa* and *Acinetobacter baumannii*: mechanisms and epidemiology. *Int J Antimicrob Agents* 45:568–585. <https://doi.org/10.1016/j.ijantimicag.2015.03.001>.
- Poirel L, Karim A, Mercat A, Le Thomas I, Vahaboglu H, Richard C, Nordmann P. 1999. Extended-spectrum beta-lactamase-producing strain of *Acinetobacter baumannii* isolated from a patient in France. *J Antimicrob Chemother* 43:157–158.
- Bonnin RA, Nordmann P, Potron A, Lecuyer H, Zahar JR, Poirel L. 2011. Carbapenem-hydrolyzing GES-type extended-spectrum beta-lactamase in *Acinetobacter baumannii*. *Antimicrob Agents Chemother* 55:349–354. <https://doi.org/10.1128/AAC.00773-10>.
- Poirel L, Menuteau O, Agoli N, Cattoen C, Nordmann P. 2003. Outbreak of extended-spectrum beta-lactamase VEB-1-producing isolates of *Acinetobacter baumannii* in a French hospital. *J Clin Microbiol* 41:3542–3547. <https://doi.org/10.1128/JCM.41.8.3542-3547.2003>.
- Endimiani A, Luzzaro F, Migliavacca R, Mantengoli E, Hujer AM, Hujer KM, Pagani L, Bonomo RA, Rossolini GM, Toniolo A. 2007. Spread in an Italian hospital of a clonal *Acinetobacter baumannii* strain producing the TEM-92 extended-spectrum beta-lactamase. *Antimicrob Agents Chemother* 51:2211–2214. <https://doi.org/10.1128/AAC.01139-06>.
- Nagano N, Nagano Y, Cordevant C, Shibata N, Arakawa Y. 2004. Nosocomial transmission of CTX-M-2 beta-lactamase-producing *Acinetobacter baumannii* in a neurosurgery ward. *J Clin Microbiol* 42:3978–3984. <https://doi.org/10.1128/JCM.42.9.3978-3984.2004>.
- Nordmann P, Ronco E, Naas T, Dupont C, Michel-Briand Y, Labia R. 1993. Characterization of a novel extended-spectrum beta-lactamase from *Pseudomonas aeruginosa*. *Antimicrob Agents Chemother* 37:962–969.
- Mantengoli E, Rossolini GM. 2005. Tn5393d, a complex Tn5393 derivative carrying the PER-1 extended-spectrum beta-lactamase gene and other resistance determinants. *Antimicrob Agents Chemother* 49:3289–3296. <https://doi.org/10.1128/AAC.49.8.3289-3296.2005>.
- Poirel L, Cabanne L, Vahaboglu H, Nordmann P. 2005. Genetic environment and expression of the extended-spectrum beta-lactamase *bla*<sub>PER-1</sub> gene in Gram-negative bacteria. *Antimicrob Agents Chemother* 49:1708–1713. <https://doi.org/10.1128/AAC.49.5.1708-1713.2005>.
- Picão RC, Poirel L, Demarta A, Petrini O, Corvaglia AR, Nordmann P. 2008. Expanded-spectrum beta-lactamase PER-1 in an environmental *Aeromonas media* isolate from Switzerland. *Antimicrob Agents Chemother* 52:3461–3462. <https://doi.org/10.1128/AAC.00770-08>.
- Xia R, Guo X, Zhang Y, Xu H. 2010. qnrVC-like gene located in a novel complex class 1 integron harboring the ISCR1 element in an *Aeromonas punctata* strain from an aquatic environment in Shandong Province, China. *Antimicrob Agents Chemother* 54:3471–3474. <https://doi.org/10.1128/AAC.01668-09>.
- Bauernfeind A, Stemplinger I, Jungwirth R, Mangold P, Amann S, Akalin E, Ang O, Bal C, Casellas JM. 1996. Characterization of beta-lactamase gene *bla*<sub>PER-2</sub> which encodes an extended-spectrum class A beta-lactamase. *Antimicrob Agents Chemother* 40:616–620.
- Orman BE, Pineiro SA, Arduino S, Galas M, Melano R, Caffer MI, Sordelli DO, Centron D. 2002. Evolution of multiresistance in nontyphoid *Salmonella* serovars from 1984 to 1998 in Argentina. *Antimicrob Agents Chemother* 46:3963–3970. <https://doi.org/10.1128/AAC.46.12.3963-3970.2002>.
- Quinteros M, Radice M, Gardella N, Rodriguez MM, Costa N, Korbenfeld D, Couto E, Gutkind G; Microbiology Study Group. 2003. Extended-spectrum beta-lactamases in *Enterobacteriaceae* in Buenos Aires, Argentina, public hospitals. *Antimicrob Agents Chemother* 47:2864–2867. <https://doi.org/10.1128/AAC.47.9.2864-2867.2003>.
- Vignoli R, Varela G, Mota MI, Cordeiro NF, Power P, Ingold E, Gadea P, Sirok A, Schelotto F, Ayala JA, Gutkind G. 2005. Enteropathogenic *Escherichia coli* strains carrying genes encoding the PER-2 and TEM-116 extended-spectrum beta-lactamases isolated from children with diarrhea in Uruguay. *J Clin Microbiol* 43:2940–2943. <https://doi.org/10.1128/JCM.43.6.2940-2943.2005>.
- Girlich D, Poirel L, Nordmann P. 2010. PER-6, an extended-spectrum beta-lactamase from *Aeromonas allosaccharophila*. *Antimicrob Agents Chemother* 54:1619–1622. <https://doi.org/10.1128/AAC.01585-09>.
- Bonnin RA, Potron A, Poirel L, Lecuyer H, Neri R, Nordmann P. 2011. PER-7, an extended-spectrum beta-lactamase with increased activity toward broad-spectrum cephalosporins in *Acinetobacter baumannii*. *Antimicrob Agents Chemother* 55:2424–2427. <https://doi.org/10.1128/AAC.01795-10>.
- Tada T, Shrestha B, Miyoshi-Akiyama T, Shimada K, Ohara H, Kirikae T, Pokhrel BM. 2014. NDM-12, a novel New Delhi metallo-beta-lactamase variant from a carbapenem-resistant *Escherichia coli* clinical isolate in Nepal. *Antimicrob Agents Chemother* 58:6302–6305. <https://doi.org/10.1128/AAC.03355-14>.
- Kaase M, Nordmann P, Wichelhaus TA, Gatermann SG, Bonnin RA, Poirel L. 2011. NDM-2 carbapenemase in *Acinetobacter baumannii* from Egypt. *J Antimicrob Chemother* 66:1260–1262. <https://doi.org/10.1093/jac/dkr135>.
- Grosso F, Quinteira S, Peixe L. 2011. Understanding the dynamics of imipenem-resistant *Acinetobacter baumannii* lineages within Portugal. *Clin Microbiol Infect* 17:1275–1279. <https://doi.org/10.1111/j.1469-0691.2011.03469.x>.
- Bertini A, Poirel L, Mugnier PD, Villa L, Nordmann P, Carattoli A. 2010. Characterization and PCR-based replicon typing of resistance plasmids in *Acinetobacter baumannii*. *Antimicrob Agents Chemother* 54:4168–4177. <https://doi.org/10.1128/AAC.00542-10>.
- Shrestha S, Tada T, Miyoshi-Akiyama T, Ohara H, Shimada K, Satou K, Teruya K, Nakano K, Shiroma A, Sherchand JB, Rijal BP, Hirano T, Kirikae T, Pokhrel BM. 2015. Molecular epidemiology of multidrug-resistant *Acinetobacter baumannii* isolates in a university hospital in Nepal reveals the emergence of a novel epidemic clonal lineage. *Int J Antimicrob Agents* 46:526–531. <https://doi.org/10.1016/j.ijantimicag.2015.07.012>.
- Toleman MA, Walsh TR. 2011. Combinatorial events of insertion sequences and ICE in Gram-negative bacteria. *FEMS Microbiol Rev* 35:912–935. <https://doi.org/10.1111/j.1574-6976.2011.00294.x>.
- Toleman MA, Bennett PM, Walsh TR. 2006. ISCR elements: novel gene-capturing systems of the 21st century? *Microbiol Mol Biol Rev* 70:296–316. <https://doi.org/10.1128/MMBR.00048-05>.
- Brown S, Amyes SG. 2005. The sequences of seven class D beta-lactamases isolated from carbapenem-resistant *Acinetobacter baumannii* from four continents. *Clin Microbiol Infect* 11:326–329. <https://doi.org/10.1111/j.1469-0691.2005.01096.x>.
- Loewen PC, Alsaadi Y, Fernando D, Kumar A. 2014. Genome sequence of a tigecycline-resistant clinical isolate of *Acinetobacter baumannii* strain AB031 obtained from a bloodstream infection. *Genome Announc* 2:e01036-14. <https://doi.org/10.1128/genomeA.01036-14>.

## Molecular and Clinical Epidemiology of *Salmonella* Paratyphi A Isolated from Patients with Bacteremia in Nepal

Jatan Bahadur Sherchan,<sup>1</sup> Masatomo Morita,<sup>2</sup> Takashi Matono,<sup>2</sup> Hidemasa Izumiya,<sup>2</sup> Makoto Ohnishi,<sup>2</sup> Jeevan B. Sherchand,<sup>3</sup> Sarmila Tandukar,<sup>3</sup> Ujjwal Laghu,<sup>3</sup> Maki Nagamatsu,<sup>4</sup> Yasuyuki Kato,<sup>4</sup> Norio Ohmagari,<sup>4</sup> and Kayoko Hayakawa<sup>4\*</sup>

<sup>1</sup>Department of Clinical Microbiology, Kathmandu University School of Medical Sciences, Dhulikhel, Nepal; <sup>2</sup>Department of Bacteriology I, National Institute of Infectious Diseases, Tokyo, Japan; <sup>3</sup>Public Health Research Laboratory, Institute of Medicine, Tribhuvan University Teaching Hospital, Kathmandu, Nepal; <sup>4</sup>Disease Control and Prevention Center, National Center for Global Health and Medicine, Tokyo, Japan

**Abstract.** Little is known about the epidemiology of typhoid and paratyphoid fever in Nepal. We aimed to elucidate the molecular and clinical epidemiology of *Salmonella* Paratyphi A in Nepal. Isolates were collected from 23 cases of bacteremia due to *S. Paratyphi* A between December 2014 and October 2015. Thirteen patients (57%) were male, and the median age was 21 years. None of the patients had an underlying chronic disease. All *S. Paratyphi* A isolates were sensitive to ampicillin, trimethoprim/sulfamethoxazole, ceftriaxone, and chloramphenicol. All isolates were resistant to nalidixic acid and were categorized as intermediately susceptible to levofloxacin. Phylogenetic analysis revealed close relatedness among the isolates, including several clonal groups, suggesting local spread. Patients with bacteremia due to *S. Paratyphi* A in Kathmandu, Nepal, were relatively young and nondebilitated. Improving control of *S. Paratyphi* infections should focus on effective infection control measures and selection of empirical therapy based on current resistance patterns.

### INTRODUCTION

*Salmonella enterica* serotype Typhi or *S. enterica* serotype Paratyphi cause an estimated 22 million new cases of enteric fever (typhoid or paratyphoid) annually, and 200,000 deaths.<sup>1</sup> Nepal is located in South Asia where typhoid and paratyphoid fever are most prevalent.<sup>2</sup> Especially, Kathmandu is known to have the significant burden of enteric fever caused by *S. Typhi* and *S. Paratyphi* A.<sup>3</sup> The recent spread of multidrug resistant *S. Typhi* and *S. Paratyphi* A is a serious threat to public health; however, little is known about the epidemiology of typhoid and paratyphoid fever in Nepal. Previous reports have suggested an increase in the incidence of paratyphoid fever, against which currently available typhoid vaccines provide little to no protection.<sup>2,3</sup> This study aimed to elucidate the molecular and clinical epidemiology including the prevalence of drug-resistant strains and phylogenetic analyses of *S. Paratyphi* A in Nepal.

### METHODS

From December 2014 to October 2015, *S. Paratyphi* A isolates were collected from patients with bacteremia at Tribhuvan University, Kathmandu, Nepal. For patients from whom more than one *S. Paratyphi* A strain was isolated during the study period, only the first episode was analyzed (i.e., unique patient episodes). Institutional review boards at the Tribhuvan University approved the study before its initiation. Parameters retrieved from the patient records included demographics, background conditions and clinical symptoms, duration of hospital stay (for patients who were hospitalized), empiric antimicrobial treatment; information on occupation and exposure (e.g., animal contact, contact to similar cases), and clinical outcome.

Minimum inhibitory concentrations (MICs) were determined by the broth microdilution method using the Dry Plate Eiken (Eiken Chemical, Tokyo, Japan), in accordance with the Clinical and Laboratory Standard Institutions (CLSI) criteria (M100-S26) at the National Center for Global Health and Medicine. Whole-genome sequencing and phylogenetic analysis were conducted at the National Institute of Infectious Diseases. Genomic DNA was prepared using the DNeasy Blood & Tissue kit (Qiagen, Hilden, Germany) according to the manufacturer's instructions. Genomic DNA libraries were prepared using the Nextera XT DNA sample prep kit (Illumina, San Diego, CA) and paired-end (300 × 2 bp) short reads for each library were sequenced on a MiSeq instrument (Illumina). Sufficient DNA sequence reads were generated to cover the genome at least 60 folds. Sequence reads were assembled with the de novo genome assembly program CLC Genomics Workbench v.8.5.1 (CLC Bio, Aarhus, Denmark) to generate a multicontig draft genome for each sample. All contigs were compared with the reference genome for *S. Paratyphi* A strain ATCC 9150 (CP000026.1) to detect mutations on *gyrA*, *gyrB*, *parC*, and *parE* genes. To compare short-read mapping data for all strains with the reference chromosomal sequence of *S. Paratyphi* A strain ATCC 9150 (CP000026.1), *bwasw*<sup>4</sup> and *samtools*<sup>5</sup> software were used with default parameters. Single nucleotide polymorphisms (SNPs) were extracted with VarScan v.2.3.4<sup>6</sup> using default parameters. The SNPs in repetitive and recombination regions were excluded for further analyses. Exact and inexact repeat regions were detected using the MUMmer v.3.23.<sup>7</sup> RechMM was used to identify recombination regions.<sup>8</sup> The remaining 254 SNPs were concatenated to generate a pseudosequence for phylogenetic analysis; maximum likelihood phylogenetic analysis was performed using RAxML v.8.2.0<sup>9</sup> with 1,000 bootstrap iterations.

### RESULTS

During the study period, 23 cases of bacteremia due to *S. Paratyphi* A, and 86 cases of bacteremia due to *S. Typhi*

\* Address correspondence to Kayoko Hayakawa, Disease Control and Prevention Center, National Center for Global Health and Medicine, 1-21-1 Toyama, Shinjuku-ku, Tokyo 162-8655, Japan. E-mail: kayokohayakawa@gmail.com

TABLE 1

Clinical characteristics of patients with bacteremia due to *Salmonella* Paratyphi A (*N* = 23)

	Number of patients (%)
<b>Demographics</b>	
Age, median (IQR)	21 (17–23)
Male patients	13 (56.5)
Inpatients/out patients	12 (52.2)/11 (47.8)
<b>Occupation</b>	
Student	12 (52.2)
House wife	4 (17.4)
Farmer/gardener	3 (13)
Driver	2 (8.7)
Nurse	1 (4.3)
Pastry shop worker	1 (4.3)
<b>Clinical symptom</b>	
Fever	23 (100)
Abdominal pain	10 (43.5)
Diarrhea	3 (13)
Vomiting	2 (8.7)
<b>Empiric antimicrobial treatment</b>	
Fluoroquinolone*	12 (52.2)
Cefixime	4 (17.4)
Ceftriaxone	2 (8.7)
Azithromycin	1 (4.3)
Duration of hospitalization, median (IQR), days	5 (3–6)

IQR = interquartile range. One patient received cefixime, azithromycin, ceftriaxone, and another patient received ceftriaxone, azithromycin, and levofloxacin.

\* Fluoroquinolones include ciprofloxacin (*N* = 10), ofloxacin (*N* = 1), and levofloxacin (*N* = 1).

were identified. Among the 23 cases of bacteremia due to *S. Paratyphi A*, 13 patients (56.5%) were male, the median age was 21 years (interquartile range [IQR]: 17–23 years, range: 5–68 years). Among the 86 cases of bacteremia due to *S. Typhi*, 51 patients (59.3%) were male, the median age was 21 years (IQR: 17–26 years, range: 4–70 years). Clinical characteristics are summarized in Table 1. Twelve (52.2%) patients were hospitalized, the other were outpatients. None of the patients had an underlying chronic disease or immunosuppressive status. Twelve patients (52.2%) were students,

four (17.4%) were housewives, three were farmers or gardeners, two (8.7%) were drivers, one (4.3%) was a nurse, and one (4.3%) worked at a pastry shop. The most common clinical symptom was fever (*N* = 23, 100%), followed by abdominal pain (*N* = 10, 43.5%), diarrhea (*N* = 3, 13%), and vomiting (*N* = 2, 8.7%). Most commonly prescribed empiric antimicrobial treatment was fluoroquinolone (*N* = 12, 52.2%), followed by cephalosporins (cefixime [*N* = 4, 17.4%], ceftriaxone [*N* = 2, 8.7%]), and azithromycin (*N* = 1, 4.3%). The median duration of hospitalization was 5 (IQR: 3–6) days, and no patient had complications or died.

Antibiotic susceptibility and MICs of the *S. Paratyphi A* isolates are listed in Table 2. All isolates were sensitive to ampicillin, trimethoprim/sulfamethoxazole, ceftriaxone, and chloramphenicol, and had an azithromycin MIC of less than 16 µg/mL. All isolates were resistant to nalidixic acid. The susceptibilities to fluoroquinolones differed, i.e., all isolates were resistant to ofloxacin based on CLSI criteria (M100-S26), four (17.4%) were resistant to ciprofloxacin, and all isolates were categorized as intermediately susceptible to levofloxacin.

Phylogenetic analyses showed that except for one strain (151006PA), all isolates clustered together, with SNP distances of 0–9 SNPs (Figure 1). Clonal isolates (genetically closest isolates with 0 SNPs) were detected in five groups, whereas definitive outbreak from food handlers (the housewives and pastry shop worker) and family infection were not found. Among the five groups of clonal isolates, each isolate was predominantly detected 1 month or more apart, and only three paired isolates had a near sampling dates: 151080PA (on July 1, 2015) and 151086PA (on July 16, 2015); 151029PA (on March 5, 2015) and 151032PA (on March 12, 2015); and 151033PA (March 15, 2015) and 151031PA (March 8, 2015). All *S. Paratyphi A* isolates had a same single mutation C248T in *gyrA* encoding Ser83Phe; however, no mutation was found in *gyrB*, *parC*, and *parE*.

TABLE 2  
Antibiotic susceptibility and minimal inhibitory concentration (MIC) of *Salmonella* Paratyphi A (*N* = 23)

Antibiotics	Antibiotic susceptibility, number of resistant* isolates (%)			MIC (µg/mL)	
	S	I	R	MIC <sub>50</sub>	MIC <sub>90</sub>
Nalidixic acid	–	–	23 (100)	> 128	> 128
Ciprofloxacin	–	19 (82.6)	4 (17.4)	0.5	1
Levofloxacin	–	23 (100)	–	1	1
Ofloxacin	–	–	23 (100)	2	2
Norfloxacin†	–	–	–	4	4
Gatifloxacin†	–	–	–	0.5	1
Prulifloxacin‡	–	–	–	0.5	0.5
Tosufloxacin‡	–	–	–	0.5	0.5
Gentamicin	23 (100)	–	–	0.12	0.25
Kanamycin	23 (100)	–	–	0.5	1
Trimethoprim- sulfamethoxazole	23 (100)	–	–	0.12/2.38	0.25/4.75
Tetracycline	23 (100)	–	–	2	4
Minocycline	23 (100)	–	–	4	4
Azithromycin‡	23 (100)	–	–	8	8
Cefotaxime	23 (100)	–	–	0.12	0.25
Ceftriaxone	23 (100)	–	–	0.12	0.25
Ampicillin	23 (100)	–	–	4	4
Aztreonam‡	–	–	–	0.12	0.12
Imipenem	23 (100)	–	–	0.25	0.25
Panipenem‡	–	–	–	0.12	0.12
Biapenem‡	–	–	–	0.25	0.25
Chloramphenicol	23 (100)	–	–	8	8

\* Based on Clinical and Laboratory Standard Institutions (CLSI) criteria 2016 (M100-S26) unless otherwise noted.

† CLSI criteria 2016 (M100-S26) did not specify *Salmonella* spp. as they did for other fluoroquinolones, and thus, antibiotic susceptibility was left blank.

‡ No breakpoint is available for *S. Paratyphi* based on CLSI criteria 2016 (M100-S26).

1708

SHERCHAN AND OTHERS

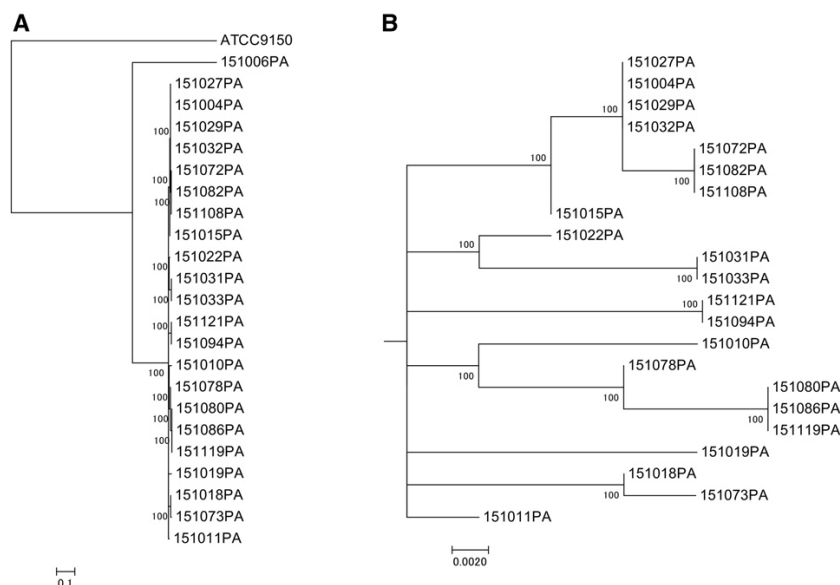

FIGURE 1. Maximum-likelihood tree generated from single nucleotide polymorphisms in the core genome. (A) Phylogenetic tree of *Salmonella* Paratyphi A isolates from Tribhuvan University, Kathmandu, Nepal. (B) Phylogenetic sub-tree of major endemic *S. Paratyphi* A isolates.

## DISCUSSION

In this study, we identified the molecular and clinical epidemiology of *S. Paratyphi* A in Kathmandu, Nepal. As we included sequential patients with bacteremia due to *S. Paratyphi* A, our findings would reflect the epidemiologic characteristics of this endemic region. It was revealed that *S. Paratyphi* A mainly affects relatively young subjects. The high prevalence of fever is consistent with recent reports on *S. Typhi* and *S. Paratyphi* bacteremia.<sup>10</sup> In our cohort, the prevalence of abdominal pain was slightly higher, whereas diarrhea and vomiting were less prevalent than in previous reports.<sup>10</sup> This might be due to differences in baseline characteristics, including age, of the tested population.

In this study, the antibiotic susceptibility and MICs revealed patterns of re-emergence of susceptibility to conventional antibiotics (e.g., chloramphenicol, trimethoprim/sulfamethoxazole, and ampicillin) similar to those described previously.<sup>11</sup> On the other hand, MICs for quinolones were elevated. Importantly, *S. Paratyphi* A isolates of 10 patients who received ciprofloxacin as empiric therapy showed ciprofloxacin MICs  $\geq 0.5$   $\mu\text{g}/\text{mL}$ , and one patient who received ofloxacin carried *S. Paratyphi* A with an ofloxacin MIC of 2  $\mu\text{g}/\text{mL}$ . Along with recent trial results on the use of gatifloxacin,<sup>10</sup> reconsideration is warranted in terms of empiric antimicrobial treatment against *S. Paratyphi* A bacteremia in Nepal.

Based on phylogenetic analyses, there seem to be two distinct endemic strains of *S. Paratyphi* A in the study region. The major endemic strain was genetically diverged as compared with outbreak-associated isolates in China.<sup>12</sup> The relatively high prevalence of patients who handle food (e.g., food-handling business, housewives) and patients who have close contact with other people (e.g., students) in this study suggests a potential point of intervention to reduce the

transmission of *S. Paratyphi*, for which no vaccine is readily available.

High relatedness, coupled with high prevalence of reduced susceptibility to fluoroquinolones, was observed in *S. Paratyphi* isolated from patients with bacteremia in Nepal, Kathmandu. Further studies are warranted in terms of appropriate effective therapy and effective infection control approaches in this region.

Received March 21, 2017. Accepted for publication July 26, 2017.

Published online October 9, 2017.

Financial support: This work was supported by a grant in Clinical Epidemiology Research, St. Luke's International University, Tokyo, Japan (2016).

Authors' addresses: Jatan Bahadur Sherchan, Department of Clinical Microbiology, Kathmandu University School of Medical Sciences, Dhulikhel, Nepal, E-mail: jatansherchan@gmail.com. Masatomo Morita, Takashi Matono, Hidemasa Izumiya, and Makoto Ohnishi, Department of Bacteriology I, National Institute of Infectious Diseases, Tokyo, Japan, E-mails: mmorita@niid.go.jp, tmatono@niid.go.jp, izumiya@nih.go.jp, and ohnishi7@nih.go.jp. Jeevan B. Sherchand, Sarmila Tandukar, and Ujjwal Laghu, Department of Microbiology and Parasitology, Tribhuvan University Teaching Hospital, Kathmandu, Nepal, E-mails: jeevansherchand@hotmail.com, sar1234tan@gmail.com, and ujjwal111@iom.edu.np. Maki Nagamatsu, Yasuyuki Kato, Norio Ohmagari, and Kayoko Hayakawa, Disease Control and Prevention Center, National Center for Global Health and Medicine, Tokyo, Japan, E-mails: dfmm217@yahoo.co.jp, ykato@hosp.ncgm.go.jp, nohmagari@hosp.ncgm.go.jp, and kayokohayakawa@gmail.com.

## REFERENCES

- Crump JA, Luby SP, Mintz ED, 2004. The global burden of typhoid fever. *Bull World Health Organ* 82: 346–353.
- Basnyat B, Maskey AP, Zimmerman MD, Murdoch DR, 2005. Enteric (typhoid) fever in travelers. *Clin Infect Dis* 41: 1467–1472.
- Karkey A, Aryal A, Basnyat B, Baker S, 2008. Kathmandu, Nepal: still an enteric fever capital of the world. *J Infect Dev Ctries* 2: 461–465.



4. Li H, Durbin R, 2010. Fast and accurate long-read alignment with Burrows-Wheeler transform. *Bioinformatics* 26: 589–595.
5. Li H, 2011. A statistical framework for SNP calling, mutation discovery, association mapping and population genetical parameter estimation from sequencing data. *Bioinformatics* 27: 2987–2993.
6. Koboldt DC, Zhang Q, Larson DE, Shen D, McLellan MD, Lin L, Miller CA, Mardis ER, Ding L, Wilson RK, 2012. VarScan 2: somatic mutation and copy number alteration discovery in cancer by exome sequencing. *Genome Res* 22: 568–576.
7. Kurtz S, Phillippy A, Delcher AL, Smoot M, Shumway M, Antonescu C, Salzberg SL, 2004. Versatile and open software for comparing large genomes. *Genome Biol* 5: R12.
8. Zhou Z, McCann A, Weill FX, Blin C, Nair S, Wain J, Dougan G, Achtman M, 2014. Transient Darwinian selection in *Salmonella enterica* serovar Paratyphi A during 450 years of global spread of enteric fever. *Proc Natl Acad Sci USA* 111: 12199–12204.
9. Stamatakis A, 2006. RAxML-VI-HPC: maximum likelihood-based phylogenetic analyses with thousands of taxa and mixed models. *Bioinformatics* 22: 2688–2690.
10. Arjyal A et al., 2016. Gatifloxacin versus ceftriaxone for uncomplicated enteric fever in Nepal: an open-label, two-centre, randomised controlled trial. *Lancet Infect Dis* 16: 535–545.
11. Shrestha KL, Pant ND, Bhandari R, Khatri S, Shrestha B, Lekhak B, 2016. Re-emergence of the susceptibility of the *Salmonella* spp. isolated from blood samples to conventional first line antibiotics. *Antimicrob Resist Infect Control* 5: 22.
12. Yan M et al., 2015. A large-scale community-based outbreak of paratyphoid fever caused by hospital-derived transmission in southern China. *PLoS Negl Trop Dis* 9: e0003859.

## Review Article

## Review of Collaboration between Tribhuvan University Institute of Medicine in Nepal and National Center for Global Health and Medicine in Japan on Nosocomial Infection Control and Proposal for Improvement

Ohara H<sup>1</sup>, Sherchan JB<sup>2</sup>, Pokhrel BM<sup>3</sup> and Sherchand JB<sup>3</sup>

<sup>1</sup>Bureau of International Medical Cooperation, National Center for Global Health and Medicine, Tokyo, Japan.

<sup>2</sup>Department of Microbiology, Kathmandu University School of Medical Sciences, Kavre, Nepal.

<sup>3</sup>Department of Microbiology, Institute of Medicine, Tribhuvan University, Kathmandu, Nepal.

**Correspondence:** Dr. Hiroshi Ohara, MD; PhD.

**Email:** ohara52jp@gmail.com

### Introduction

In developing countries, where the incidence of infectious diseases is high and environmental conditions of healthcare facilities are poor, nosocomial infections may frequently occur.<sup>1,2,3</sup> Effective nosocomial infection control is crucial in the healthcare facilities of developing countries, but in actual fact, attention to it is still limited and control measures are not functioning well in many countries<sup>4</sup>. Furthermore, bacterial resistance to antibiotics is increasing worldwide and this fact is not a little affecting nosocomial infection. However studies about the actual situation of multi-drug resistant bacteria in developing countries along with measures to address such situation is still limited.<sup>5</sup>

Collaboration between Institute of Medicine, Tribhuvan University (IOM) in Kathmandu City, which is the core of medical services in Nepal and National Center for Global Health and Medicine (NCGM) in Japan has a long history, which dates back to the Medical Education Project by JICA. During the project period, various technical cooperation was implemented, however, technical guidance on nosocomial infection control was not included.

In view of the growing concern on nosocomial infection control and spread of antimicrobial resistant bacteria in recent years and based on the reliable relationship created through the project, IOM and NCGM decided a new collaboration focusing on research of nosocomial infection control including anti-microbial resistance (AMR). These collaborative activities were designed and conducted with the purpose to investigate the

actual conditions of nosocomial infection control in Kathmandu City, Nepal as a basis for the possible contribution to its improvement.<sup>6</sup>

After reviewing the preceding researches and the technical cooperation, the following 3 researches were carried out in Nepal during January 2011- March 2016, followed by discussion and proposals for improvement. In this paper, we summarized these collaborative activities between the two institutions.

- Fact-finding survey of nosocomial infection control in hospitals in Kathmandu, Nepal- a basis for improvement
- Study on nosocomial bacterial pattern in Tribhuvan University Teaching Hospital
- Study on AMR in Nepal
- Study on medical personnel regarding nosocomial infection control (KAP survey)

### Initiation of cooperation between IOM and NCGM

IOM was constructed by Japan's Grant Aid in 1980. Technical cooperation project by Japan International Cooperation Agency (JICA) had been implemented from 1980 to 1996 (Medical Education Project) with the purpose to establish medical education and strengthen the function of IOM including the Tribhuvan University Teaching Hospital (TUTH). NCGM dispatched chief advisors and experts to provide technical guidance. During the 16 years the project conducted various activities, aiming to achieve the purpose, to strengthen

hospital administration, education and training management, clinical medicine, basic science, nursing management, etc., however nosocomial infection control was not included. That was because in those days awareness on nosocomial infection control was still low not only in developing countries but also in developed countries.<sup>7</sup>

Nepal suffered political instability from 1996 to 2006 followed by a transition from the Kingdom of Nepal to the Federal Democratic Republic of Nepal in 2008. However, with the stabilizing of political conditions relationship between IOM and NCGM has recovered. In 2009, the Joint Symposium on Nosocomial Infection Control was held at IOM jointly organized by IOM and NCGM, resulting in recognition of the importance of nosocomial infection control and research collaboration.

### Collaboration in research on nosocomial infection control and AMR

The following researches were carried out. Outlines are described briefly. For detailed information please refer to the publications indicated in each item.

#### 1. Fact-finding survey of nosocomial infection control in hospitals in Kathmandu, Nepal- a basis for improvement:

This survey was carried out as a baseline study aiming to contribute to the improvement of nosocomial infection control at TUTH/IOM and consequently hospitals in Kathmandu City during 2011-2013. The primary purpose of this study was to evaluate nosocomial infection control conditions and to prepare the basic information needed to provide technical guidance. The actual condition of nosocomial infection control was examined at 17 leading hospitals in Kathmandu City with the method of questionnaire, site visits and key informant interviews. The obtained results were compared with the results of the past survey in 2003.<sup>8</sup>

The results showed gradual improvement in nosocomial infection control situation but further improvement is needed, particularly in practice in basic technics. Increase of antibiotics resistant bacteria was also suggested. Both the frequency of the meetings of nosocomial infection control committee and the frequency of ICT rounds by infection control teams increased. Also, some

improvement in the monitoring of causative agents and in the information provision system for clinical settings were recognized. Issues to be addressed included improving the quality of the control system and training program, providing training to a wider range of staff members, improving waste disposal system, updating manuals, etc<sup>9</sup>. Among the targeted hospitals in this survey, TUTH showed comparatively good results. Bacteriological testing, guided by the JICA project, was functioning well and contributing to the surveillance of nosocomial infections. (Fig. 1,2,3,4)

These findings clearly reflected that there was a need of further improvement of nosocomial infection control with constant efforts focusing on training of medical staff to enhance basic fundamental techniques, enhancement of awareness, strengthening control system and preparation of necessary equipment.

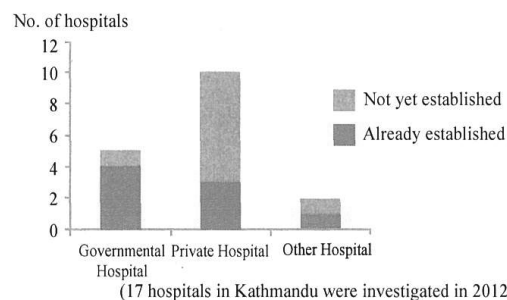

Figure 1: Hospitals with infection control committee.

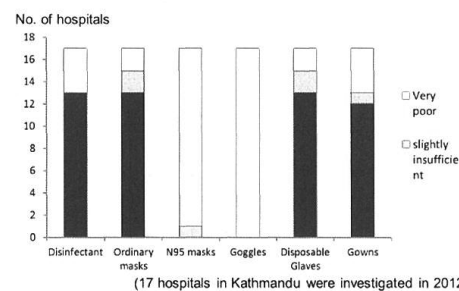

Figure 2: Hospitals satisfying standard requirement of personal protective equipment (PPE) and disinfectants.

Review of Collaboration between ...

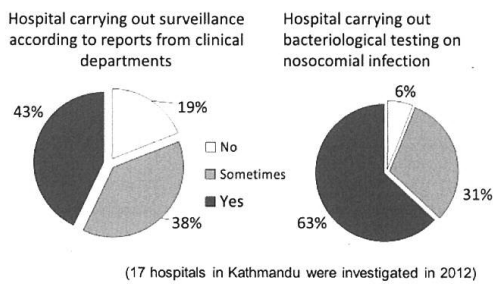

Figure 3: Surveillance situation

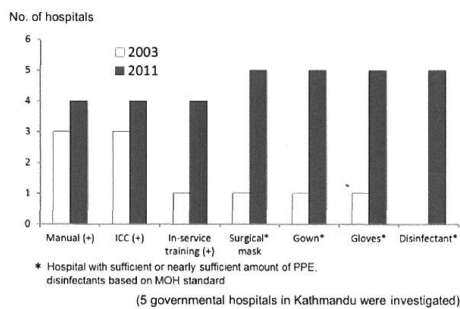

Figure 4 : Comparison of infection control situation between 2003 and 2011

2. Study on nosocomial bacterial pattern in Tribhuvan University Teaching Hospital:

This study was conducted with the aim to determine the bacteria causing nosocomial infections and their antibiotics resistant pattern. Total of 310 clinical specimens obtained from nosocomial infection cases were examined bacteriologically. Out of the 310 specimens (urine, sputum, pus, endotracheal secretion, blood) 333 bacteria were isolated. The most common isolates were *E. coli* followed by Acinetobacter species, *Klebsiella pneumoniae* and *Staphylococcus aureus*. The isolated bacteria showed high resistance to antibiotics. These findings suggested the necessity of constant monitoring of susceptibility of specific pathogens to commonly used anti-microbial agents along with preventive measures from dissemination of resistant strains.<sup>10</sup> (Table 1)

Table 1: Methicillin resistant *Staphylococcus aureus*

Specimens	Number of isolates	MRSA (%)
Urine	11	54.5
Sputum	15	66.7
Pus	15	66.7

41 clinical isolates were examined at TUTH

3. Study on AMR in Nepal

Emergence of multidrug-resistant pathogens has become one of the most serious problems in medical settings worldwide. There are serious concerns about dissemination of multi-drug-resistant nosocomial pathogens in Nepal. Firstly, we conducted studies on nosocomial respiratory infections and it suggested high frequency of multi-drug resistant bacteria.<sup>11,12</sup> (Fig. 5,6,7)

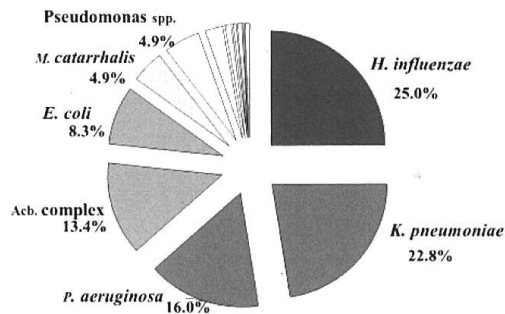

Figure 5: Distribution of gram-negative bacterial isolates (n=533)

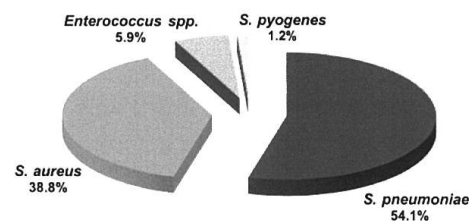
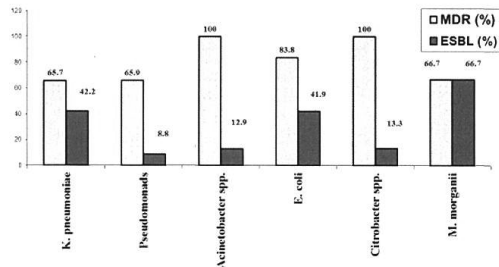

Figure 6: Distribution of positive-negative bacterial isolates (n=85)

104



Department of Microbiology, Tribhuvan University Teaching Hospital

**Figure 7: Multi drug resistance (MDR) vs. Extended Spectrum Beta Lactamase (ESBL) producing bacteria.**

Then we conducted a study on drug resistant pathogens isolated from inpatients in TUTH. During the period April 2012- November 2014, a total of 308 gram-negative bacteria were isolated from nosocomial infection cases including *Acinetobacter baumannii*, *Escherichia coli*, *Klebsiella pneumoniae*, *Pseudomonas aeruginosa*, *Providencia rettgeri*, *Serratia marcescens* and *Stenotrophomonas maltophilia*. These isolates and some other isolates were analyzed bacteriologically and genetically, and the following precious findings were obtained. These findings were reported in international journals along with at assembly of medical societies.

- 1) The new variant of New Delhi methalo- $\beta$ -lactamase producers were identified from *Escherichia coli* and named NDM-8 and NDM-12 respectively (the first case in the world).<sup>13,14</sup>
- 2) "AAC (6')-Iak" gene in *Stenotrophomonas maltophilia* was identified (the first case in Nepal).<sup>15</sup>
- 3) *Providencia rettgeri* producing NDM-1 Metallo- $\beta$ -Lactamase and Arma 16S rRNA Methylase was detected (the second case in the world).<sup>16</sup>
- 4) The new variant of New Delhi methalo- $\beta$ -lactamase producers were identified from *Escherichia coli* in 2015 and named NDM-13.<sup>17</sup>
- 5) Multiple drug resistant bacteria with strong resistance to Carbapenem and Aminoglycoside were isolated.<sup>18,19</sup>
- 6) AAC (6')-Ial gene was identified for the first time in *Serratia marcescens*.<sup>20</sup>

Ohara H, et al.,

Particularly it is outstanding that 3 new strains of New Delhi metallo- $\beta$ -lactamase producer (NDM) were discovered among the nosocomial infection cases and named NDM-8, 12, and 13.<sup>13,14,17</sup>

These findings suggested a significant increase in drug resistance of gram negative bacilli, which are facilitating nosocomial infections, in medical settings in Nepal. (Table 2)

Table 2: Discovery of NDM variants in the world

NDM variants	Organism and country	Reference
NDM-1	<i>E. coli</i> and <i>K. pneumoniae</i> (Sweden)	Yong D. et. al., 2009
NDM-2	<i>Acinetobacter baumannii</i> (Egypt)	Kaase M. et. al., 2011
NDM-3	<i>E. coli</i> (Australia)	Rogers B.A. et. al., 2013
NDM-4	<i>E. coli</i> (India)	Nordmann P. et. al., 2012
NDM-5	<i>E. coli</i> (United Kingdom)	Hornsey M. et. al., 2011
NDM-6	<i>E. coli</i> (New Zealand)	Williamson D.A. et. al., 2012
NDM-7	<i>E. coli</i> (Canada)	Accession no. JX262694
NDM-8*	<i>E. coli</i> (Nepal)	Tada T. et. al., 2013*
NDM-9	<i>K. pneumoniae</i> (China)	Accession no. KC999080
NDM-10	<i>K. pneumoniae</i> (India)	Accession no. KF361506
NDM-11	Assigned (not known)	www.lahey.org/studies
NDM-12*	<i>E. coli</i> (Nepal)	Tada T. et. al., 2014*
NDM-13*	<i>E. coli</i> (Nepal)	Shrestha B., Tada T. et. al., 2015*

#### 4. Study on Medical Personnel regarding Nosocomial Infection Control (KAP survey):

This study was carried out with the aim to assess the level of awareness and actual practice of "hand-washing", which is a basic prevention method of nosocomial infection control among medical personnel, and then use the obtained results for improvement. Total of 163

## Review of Collaboration between ...

105

medical personnel (doctors, nurses and laboratory technicians) at Tribhuvan University Teaching Hospital (TUTH) were subjects of this study. A questionnaire, direct observation at important departments, and discussions were used. The following results were obtained

**Table 3: Knowledge on hand hygiene among hospital staff: Answer to the question "What is the purpose of hand Washing?"**

Respondents (Professions)	To prevent Infection from Pt. to pt. (%)	To be clean (%)	For self-protection (%)	Both to prevent infection & self-protection (%)
Doctors=27	7 (25.2)	0	0	20 (74.1)
Nurse=86	54 (62.8)	1 (1.2)	14 (16.3)	17 (19.7)
Ward attendants=32	8 (25.0)	21 (65.6)	2 (6.3)	1 (8.1)
Laboratory technicians =18	6 (33.3)	2 (11.1)	1 (5.6)	9 (50)
Total=163	75 (46.0)	24 (14.7)	17 (10.4)	47 (28.9)

- **Knowledge:** 74.1% of doctors had an accurate knowledge of hand-washing (significance, timing, methods and effects), while only 19.7% of nurses and 50.0% of laboratory technicians had such knowledge.
- **Attitude:** 83.3% of laboratory technicians, 59.3% of nurses and 29.6% of doctors considered that they had an accurate knowledge. Regarding motive of hand-washing, fear for infections during medical practices accounted for a relatively high proportion (55.5% in doctors). Reasons given for not practicing hand-washing as instructed were: "I was busy" (46.0%), "I thought it wasn't necessary because I wore gloves" (33.1%), "Something urgent came up" (11.7%). 38.7% answered that hand-washing is important. Poor levels of hand-washing practice among newly hired personnel and the importance of education for newly hired staff members were indicated.
- **Practice:** The following results were obtained regarding the degree of hand-washing in actual practice: "Prior to contact with patients" (55.8%), "After contact with patients" (97.5%), and "At the end of work" (96.1%). Practice levels were higher in nurses than in doctors. Drying and wiping methods were: hand dryer (52.7%), shared-use towels (22.7%), personal towel or handkerchief (12.3%), and natural drying (3.7%).

The study indicated that doctors at TUTH have a relatively good knowledge regarding hand-washing, but do not follow it in actual practice. A large number

of nurses and laboratory technicians lack knowledge, and have a low degree of hand-washing in actual practice prior to contact with patients. It is important to provide improved training for medical staff regarding nosocomial infection control and prevention, which are mainly based on standard precautions.<sup>21</sup> (Table 3)

### Training for newly recruited nurses in nosocomial infection control

Following the proposal of the nursing department of TUTH/IOM a training program for newly recruited nurses was improved and intensified training course on nosocomial infection control for newly recruited nurse was conducted in 2015. In advance of organizing the training course, NCGM provided training equipment such as a computer and a projector.

### Joint Conferences

The Joint Conferences on Infectious Diseases with Growing Concern in Recent Years in Nepal were organized in January 2013 and December 2014 in collaboration between IOM and NCGM. At these conferences collaborative researches and activities including nosocomial infection control and AMR were presented followed by active discussion aiming for improvement.

### Discussion

The results of the fact-finding study revealed the actual situation of nosocomial infection control and existing problems in Nepal. The awareness on nosocomial

infection control among medical staff in Kathmandu City, Nepal is increasing in recent years and the major hospitals are making efforts to improve the nosocomial infection control, however, the situation is still poor, requiring more efforts.

As the results of our studies, in medical settings in Nepal, a significant growth in drug resistance of gram negative bacilli was clearly observed. Particularly it is noteworthy that multiple drug resistant bacteria with strong resistance to Carbapenem and Aminoglycoside were isolated and new strains of New Delhi metallo-beta lactamase producing bacteria were identified. Besides, another study revealed widespread of ESBL-producing *E. coli*<sup>22</sup> and Rotavirus in hospitals.<sup>23</sup> These results revealed the spread of multi-drug resistant bacteria in medical settings in Nepal. Measures must be urgently taken to address this situation. To implement measures effectively, active intervention not only by medical facilities but also by governmental agencies, furthermore inter-sectoral collaboration, is needed.<sup>24</sup>

The spread of drug resistant bacteria in medical settings is one of the emerging health priority issues and suspected to be one of the leading causes of nosocomial infections.<sup>25,26</sup> As the cause of the increasing resistance, the following factors are suspected: abuse of antibiotics, inadequate information on bacterial resistance to antibiotics, inappropriate feedback of the information on bacterial resistance to clinical practice, inappropriate stewardship of antibiotics, increasing population movement across the border, antibiotics abuse in domestic animals, lack of inter-sectoral collaboration among relevant institutions, poor health knowledge of local residents, etc.

Handwashing is the most fundamental technic for nosocomial infection control. The results of the KAP survey indicated that the degree of hand washing prior to patient contact was low. Doctors at TUTH have a relatively good knowledge regarding hand washing, but do not follow it in actual practice. The greatest motivation for hand washing was fear of contracting diseases, whilst lack of hand washing products such as soap, water as well as forgetfulness were major constraints to hand washing. It is recommended that hospital should provide education for the staff on the importance of hand washing and prepare facilities for hand washing along with soap and disinfectants.

During the SARS outbreak in 2013 many Asian countries were affected and nosocomial infections frequently

occurred, causing a lot of casualties. It is true that this outbreak demonstrated the importance of nosocomial infection control and promoted the awareness on it.<sup>27,28</sup> Nepal fortunately did not experience a large outbreak of nosocomial infection as did in many Asian countries. In Nepal in recent years there is a growing concern to improve nosocomial infection control but awareness on nosocomial infection control is still low and opportunities to take technical guidance is limited.

In view of these circumstances, emphasis must be placed on observance of basic techniques (standard precautions) such as hand washing and the wearing of masks. The enlightenment activities, such as distribution of manuals and teaching materials and the organizing of training courses for the medical staff, are very useful and effective for the improvement of nosocomial infection control. Training course for newly recruited nurses should be continued and expanded across the country. Moreover, detailed status of nosocomial infection and causative agents should be strictly monitored, and antibiotics must be correctly used.<sup>29,30</sup>

One of the authors had conducted technical cooperation and researches in nosocomial infection control in Vietnam. The Ministry of Health in Vietnam has attached high importance to nosocomial infection control since 2000 and JICA projects supported to enhance it. As a result, nosocomial infection control has been strengthened and constant efforts to upgrade the skills and knowledge of medical staff has been continued by medical staff. In addition, experiencing the SARS outbreak and its containment awareness on nosocomial infection among medical staff increased. Strengthening nosocomial infection control was useful to enhance the quality of medical care.<sup>31,32</sup>

Nosocomial infection control is a crucial factor to provide high-quality medical care. In addition effective nosocomial infection control will reduce hospitalization and unnecessary costs for hospitals.<sup>33,34</sup> The findings we have obtained would be useful evidence in starting to establish effective control systems and measures. Importance should be placed, in particular, on the training of medical staff to enhance fundamental skills and to establish a proper control system. The constant effort and preparedness will contribute to enhance the quality of medical care and make it possible to apply stringent nosocomial infection control promptly when emerging infectious diseases occur. To implement nosocomial infection control effectively, active intervention not only by medical facilities but also by

**Review of Collaboration between ...**

107

governmental organizations, furthermore inter-sectoral collaboration, is needed.

**Proposal**

The authors stress the following importance:

- 1) It is warranted to improve nosocomial infection control in hospitals.
- 2) At hospital levels, it is important to enhance the awareness of medical staff provide training, establish appropriate control system on nosocomial infection control along with improvement of stewardship of antibiotics.
- 3) Multi-drug resistant bacteria are spreading in medical settings, requiring urgent measures.
- 4) To address the above issues not only efforts of hospitals but also strong leadership of government is needed.
- 5) It is necessary to monitor nosocomial infection control situation at all levels of healthcare facilities.
- 6) National Level Infection Control Committee should be formed.

**Conflict of interest: None declared.****Acknowledgements**

The authors wish to express our sincere gratitude to Prof. Deepak Prakash Mahara, Executive Director of TUTH, and hospitals in Kathmandu City for their cooperation in implementing these studies. These studies were conducted with the support of grants from the National Center for Global Health and Medicine, Japan with the approval of ethical committee of the Institute of Medicine, Tribhuvan University.

**References**

1. Rosenthal VD. Health-care-associated infections in developing countries. *Lancet* 2011; 377:186-188.
2. Wolkewitz M, Di Termini S, Cooper B, Meerpohl J, Schumacher M. Paediatric hospital-acquired bacteraemia in developing countries. *Lancet* 2012; 379: 1484.
3. Aiken AM, Wanyoro AK, Mwangi J, Mulingwa P, Wanjohi J, Njoroge J, Juma F, Mugoya IK, Scott JAG, Hall AJ. Evaluation of surveillance for surgical site infections in Thika Hospital, Kenya. *J Hosp Infect* 2013; 83:140-145.
4. Marcel JP, Alfa M, Baquero F, Etienne J, Goossens H, Harbarth S, Hryniewicz W, Jarvis W, Kaku M, Leclercq R, Levy S, Mazel D, Nercelles P, Perl T, Pittet D, Vanderbroucke-Grauls C, Woodford N, Jarlier V. Healthcare-associated infections: think globally, act locally. *Clin Microbiol Infect* 2008, 14(10): 895-907.
5. O'Neill J. Review on antimicrobial resistance tackling drug resistant infections globally, final report and recommendations. Wellcome Trust and the UK Department of Health, London, UK, pp1-79, May 2016.
6. IOM-NCGM Research Collaboration Office. Annual Reports 2013-2015. Available at: <http://www.ncgm.go.jp/kyokuhp/library/annual/index.html>
7. Harbarth S. What can we learn from each other in infection control? Experience in Europe compare with the USA. *J Hosp Infect* 2000;45:81-84.
8. Ohara H, Nguyen VH, Truong A, Tran Q. Report on Japan-Vietnam collaboration in nosocomial infection control in Bach Mai Hospital, Hanoi from 2000 to 2006. *Trop Med Health* 2007; 35:253-259.
9. Ohara H, Pokhrel BM, Dahal RK, Mishra SK, Kattel HP, Shrestha DL, Haneishi Y, Sherchand JB. Fact-finding survey of nosocomial infection control in hospitals in Kathmandu, Nepal: A baseline of improvement. *Trop Med Health* 2013; 3: 113-119.
10. Sah MK, Mishra SK, Ohara H, Kirikae T, Sherchand JB, Rijal BP, Pokhrel BM. Nosocomial bacterial infection and antimicrobial resistant pattern in a tertiary care hospital in Nepal. *J Inst Med* 2014; 36(3): 38-48.
11. Shrestha S, Chaudhari R, Karmacharya S, Kattel HP, Mishra SK, Dahal RK, Bam N, Banjade N, Rijal BP, Sherchand JB, Ohara H, Koirala J, Pokhrel BM. Prevalence of nosocomial lower respiratory tract infections caused by multi drug resistance pathogens. *J Inst Med*. 2011; 33: 7-14.
12. Shrestha RK, Dahal RK, Mishra SK, Parajuli K, Rijal BP, Sherchand JB, Kirikae T, Ohara H, Pokhrel BM. Ventilator associated pneumonia in tertiary care hospital, Maharajgunj, Kathmandu, Nepal. *J Inst Med* 2013; 35(3): 21-28.
13. Tada T, Miyoshi-Akiyama T, Dahal RK, Sah MK, Ohara H, Shimada K, Kirikae T. Pokhrel BM NDM-8 metallo-β-lactamase in a multidrug-resistant *Escherichia coli* strain isolated in Nepal. *Antimicrob Agents Chemother* 2013; 57(5): 2394-2396.
14. Tada T, Shrestha B, Miyoshi-Akiyama T, Shimada K, Ohara H, Kirikae T, Pokhrel BM. NDN-12, a Novel New Delhi Metallo-β-Lactamase Variant from a Carbapenem-Resistant *Escherichia coli* Clinical Isolate in Nepal. *Antimicrob Agents Chemother* 2014; 58(10): 6302-6305.
15. Tada T, Miyoshi-Akiyama T, Dahal RK, Shyam MK, Shimada K, Ohara H, Kirikae T, Pokhrel BM. Identification of a Novel 6'-N-Aminoglycoside Acetyltransferase,



- AAC(6<sup>+</sup>)-lax from a Multidrug-resistant Clinical Isolates of *Stenotrophomonas maltophilia*. Antimicrob Agents Chemother 2014; 58(10): 6324-6327.
16. Tada T, Miyoshi-Akiyama T, Dahal RK, Sah MK, Ohara H, Shimada K, Kirikae T, Pokhrel BM. NDM-1 metallo-β-lactamase and ArmA 16S rRNA methylase producing *Providencia rettgeri* clinical isolates in Nepal. BMC Infect Dis 2014; 14: 56-60.
  17. Shrestha B, Tada T, Miyoshi-Akiyama T, Shimada K, Ohara H, Kirikae T, Pokhrel BM. Identification of a novel NDM variant, NDM-13, from a multidrug-resistant *Escherichia coli* clinical isolate in Nepal. Antimicrob Agents Chemother 2015; 59(9): 5847-5850.
  18. Tada T, Miyoshi-Akiyama T, Dahal RK, Mishra SK, Ohara H, Shimada K, Kirikae T, Pokhrel BM. Dissemination of multidrug-resistant *Klebsiella pneumoniae* clinical isolates with various combinations of carbapenemases (NDM-1 and OXA-72) and 16S rRNA methylases (ArmA, RmtC and RmtF) in Nepal. Int J Antimicrob Agents 2014; 42(4): 372-374.
  19. Shrestha S, Tada T, Miyoshi-Akiyama T, Ohara H, Shimada K, Satou K, Teruya K, Nakano K, Shiroma A, Sherchand JB, Rijal BP, Hirano T, Kirikae T, Pokhrel BM. Molecular epidemiology of multidrug-resistant *Acinetobacter baumannii* isolate in a university hospital in Nepal reveals the emergence of a novel epidemic clonal lineage. Int J Antimicrob Agents 2015; 46: 526-531.
  20. Tada T, Miyoshi-Akiyama T, Shimada K, Dahal RK, Mishra SK, Ohara H, Kirikae T, Pokhrel BM. A novel 6<sup>+</sup>-N aminoglycoside acetyltransferase, AA(6<sup>+</sup>)-lai, from a clinical isolate of *Serratia marcescens*. Microbial Drug Resist 2015; DOI: 10.1089/mdr.2015.0126
  21. Sherchand S, Ohara H. Report on Knowledge, Attitude and Hand washing Practices among Health Care Professionals Working in Teaching Hospital, Kathmandu Nepal. pp.1-14, 2014.
  22. Sherchan JB, Hayakawa K, Miyoshi-Akiyama T, Ohmagari N, Kirikae T, Nagamatsu M, Tojo M, Ohara H, Sherchand JB, Tandukar S. Clinical epidemiology and molecular analysis of extended-spectrum-β-Lactamase-producing *Escherichia coli* in Nepal: characteristics of sequence types 131 and 648. Antimicrob Agents and Chemother 2015; 59(6):3424-3432.
  23. Sherchan JB, Ohara H, Sherchand JB, Tandukar S, Sakurada S, Gurung B, Ansari S, Rijal BP, Pokhrel BM. Molecular evidence based hospital acquired rotavirus gastroenteritis in Nepal. Prime J Microbiol Research 2011; 1(2): 16-21.
  24. Jarlier V, Carlet J, McGowan J, Goossens H, Voss A, Harbarth S, Pittet D. Priority actions to fight antibiotic resistance: results of an international meeting. Infect Control 2012; 1:17. DOI: 10.11186/2047-2994-1-17.
  25. Tanwar J, Das S, Fatima Z, Hameed S. Multidrug Resistance: an emerging crisis. Interdisciplinary Perspectives on Infectious Diseases 2014, Article ID 541340.
  26. Nikaido H. Multidrug resistance in bacteria. Annual Review of Biochemistry 2009, 78:119-146.
  27. Ohara H. Experience and review of SARS control in Vietnam and China. Trop Med Health 2004; 32 : 235-240.
  28. Ohara H, Kirikae T, Matsushita T, Kawana A, Teruya K. Final Report "Urgent study on Severe Acute Respiratory Syndrome (SARS) control"-Grant for International Health Cooperation Research (15A-2) from the Ministry of Health, Labour and Welfare. 2006; pp.1-179. Mizuho Press, Tokyo, Japan.
  29. P.Shears. Antibiotic resistance in the tropics-epidemiology and surveillance of antimicrobial resistance in the tropics. Trans R Soc Trop Med Hyg 2001; 95: 27-130.
  30. Okeke IN. Socioeconomic and behavioral factors leading to acquired bacterial resistance to antibiotics in developing countries. Emerg Infect Dis 1999; 5:18-27.
  31. Ohara H, Nguyen VH, Truong AT, Tran Q. Report on Japan-Vietnam collaboration in nosocomial infection control in Bach Mai Hospital, Hanoi from 2000 to 2006. Trop Med Health 2007; 35: 253-59.
  32. Ohara H, Hung NV, Truong AT. Fact-finding survey of nosocomial infection control in hospitals in Vietnam and application to training programs. J Infect Chemother 2009; 15: 384-389.
  33. Vrijens F, Hulstaert F, Devriese S, van de Sande S. Hospital-acquired infections in Belgian acute-care hospital: an estimation of their global impact on mortality, length of stay and healthcare costs. Epidemiol Infect 2012; 140: 126-136.
  34. Elizabeth A, Andreassen S, Jacobsen CM, Freiesleben de Blasio B, White R, Kristiansen IS, Elstrom P. The impact of methicillin-resistant *S. aureus* on length of stay, readmissions and costs: a register based case-control study of patients hospitalized in Norway. J. Antimicrob Resistance Inf Control. 2017 6:74, DOI:10.1186/s13756-017-0232.

AMERICAN  
SOCIETY FOR  
MICROBIOLOGYAntimicrobial Agents  
and Chemotherapy®

EPIDEMIOLOGY AND SURVEILLANCE



## *Pseudomonas aeruginosa* Clinical Isolates in Nepal Coproducing Metallo- $\beta$ -Lactamases and 16S rRNA Methyltransferases

Tatsuya Tada,<sup>a,b</sup> Kayo Shimada,<sup>a</sup> Kazuhito Satou,<sup>c</sup> Takashi Hirano,<sup>c,d</sup> Bharat M. Pokhrel,<sup>e</sup> Jeevan B. Sherchand,<sup>e</sup> Teruo Kirikae<sup>a,b</sup>

Department of Infectious Diseases, Research Institute, National Center for Global Health and Medicine, Tokyo, Japan<sup>a</sup>; Department of Microbiology, Juntendo University School of Medicine, Tokyo, Japan<sup>b</sup>; Okinawa Institute of Advanced Sciences, Okinawa, Japan<sup>c</sup>; SENTAN Pharma, Inc., Fukuoka, Japan<sup>d</sup>; Tribhuvan University, Institute of Medicine, Department of Microbiology, Maharajgunj, Kathmandu, Nepal<sup>e</sup>

**ABSTRACT** A total of 11 multidrug-resistant *Pseudomonas aeruginosa* clinical isolates were obtained in Nepal. Four of these isolates harbored genes encoding one or more carbapenemases (DIM-1, NDM-1, and/or VIM-2), and five harbored genes encoding a 16S rRNA methyltransferase (RmtB4 or RmtF2). A novel RmtF variant, RmtF2, had a substitution (K65E) compared with the same gene in RmtF. To our knowledge, this is the first report describing carbapenemase- and 16S rRNA methyltransferase-coproducing *P. aeruginosa* clinical isolates in Nepal.

**KEYWORDS** 16S rRNA methylase, *Pseudomonas aeruginosa*, carbapenemase, multidrug resistance

**M**etallo- $\beta$ -lactamases (MBLs) confer resistance to all  $\beta$ -lactams, except the monobactams, and are characterized by their efficient hydrolysis of carbapenems (1). The metallo- $\beta$ -lactamase DIM-1 was first identified in a *Pseudomonas stutzeri* strain obtained from a Dutch patient in 2007 (2). DIM-1 hydrolyzes broad-spectrum cephalosporins and carbapenems but not monobactams. Since then, DIM-1 producers, including *P. stutzeri* and *Enterobacteriaceae* spp., have been isolated in India (3) and Sierra Leone (4), respectively.

Acquired 16S rRNA methyltransferase genes responsible for an extremely high level of resistance against various aminoglycosides are widely distributed among *Enterobacteriaceae* and glucose-nonfermentative bacteria (5). To date, 10 different 16S rRNA methyltransferases, including ArmA, RmtA, RmtB, RmtC, RmtD, RmtE, RmtF, RmtG, RmtH, and NpmA, have been found in clinical isolates (6–9). One of these, RmtB, was found to have three variants, RmtB2 (accession no. JN968578), RmtB3 (accession no. JN968579), and RmtB4 (accession no. KM999534). The 16S rRNA methyltransferase RmtF was first identified in a clinical isolate of *Klebsiella pneumoniae* on the island of Réunion in 2011 (7). Since then, RmtF-producing *Enterobacteriaceae* have been isolated in India, the United Kingdom, the United States, and Nepal (7, 10, 11).

Between 2012 and 2013, 11 multidrug-resistant *Pseudomonas aeruginosa* clinical isolates were obtained from 11 inpatients treated at a university hospital in Nepal. Multidrug-resistant *Pseudomonas aeruginosa* isolates are defined as strains showing resistance to carbapenem (MIC  $\geq 16$   $\mu\text{g/ml}$ ), amikacin (MIC  $\geq 32$   $\mu\text{g/ml}$ ), and fluoroquinolone (MIC  $\geq 4$   $\mu\text{g/ml}$ ), as previously described (12). Of these isolates, 7 were from sputum, 3 from urine samples, and 1 from a pus sample. The MICs of various antibiotics were determined using the microdilution method, according to the guidelines of the Clinical and Laboratory Standards Institute (13). The entire genomes of these isolates

Received 3 April 2017 Returned for modification 27 April 2017 Accepted 24 June 2017

Accepted manuscript posted online 10 July 2017

**Citation** Tada T, Shimada K, Satou K, Hirano T, Pokhrel BM, Sherchand JB, Kirikae T. 2017. *Pseudomonas aeruginosa* clinical isolates in Nepal coproducing metallo- $\beta$ -lactamases and 16S rRNA methyltransferases. Antimicrob Agents Chemother 61:e00694-17. <https://doi.org/10.1128/AAC.00694-17>.

**Copyright** © 2017 American Society for Microbiology. All Rights Reserved.

Address correspondence to Tatsuya Tada, [ttada@ri.ncgm.go.jp](mailto:ttada@ri.ncgm.go.jp).

Downloaded from <http://aac.asm.org/> on December 25, 2017 by Kohnodai Hospital, National Center for Global Health and Medicine

were sequenced by MiSeq (Illumina, San Diego, CA). Their genomes were searched for drug resistance genes, including genes encoding  $\beta$ -lactamases (carbapenemases and extended-spectrum  $\beta$ -lactamases), 16S rRNA methyltransferases, and aminoglycoside-acetyl/adenyltransferases, using ResFinder 2.1 (<https://cge.cbs.dtu.dk/services/ResFinder/>). Point mutations associated with quinolone resistance were searched in *gyrA* and *parC*. Multilocus sequence type (MLST) was deduced, as described by the protocols of the PubMLST (<http://pubmlst.org/paeruginosa/>) databases. The complete genome of *P. aeruginosa* IOMTU133 was determined using PacBio RS II (Menlo Park), as described previously (14). The genomic environments surrounding genes encoding carbapenemases and/or 16S rRNA methyltransferases were confirmed by Sanger sequencing. DNA plugs of all isolates tested (digested with I-CeuI or S1 nuclease) were prepared and separated by pulsed-field gel electrophoresis, and Southern hybridization was performed using probes of 16S rRNA, *bla*<sub>DIM-1</sub>, *bla*<sub>NDM-1</sub>, *bla*<sub>VIM-2</sub>, *rmtB4*, and *rmtF2* (15, 16).

All 11 isolates were resistant to meropenem, aztreonam, amikacin, and ciprofloxacin (Table 1), with MICs  $\geq 16$   $\mu\text{g/ml}$ . Three isolates showed higher MICs to imipenem or meropenem,  $\geq 64$   $\mu\text{g/ml}$ , than the other isolates. Five of the 11 isolates were extremely highly resistant to amikacin and arbekacin, with MICs  $>1,024$   $\mu\text{g/ml}$ , and to ciprofloxacin, with MICs of 32 to 256  $\mu\text{g/ml}$ . All isolates were susceptible to colistin, with MICs  $\leq 0.5$   $\mu\text{g/ml}$ .

Of the 11 isolates, three had a novel *rmtF* variant, designated *rmtF2* (accession no. LC050387). Analysis of its predicted amino acid sequence revealed a substitution (K65E) compared with the sequence of RmtF. Four isolates had genes encoding one or more metallo- $\beta$ -lactamases, i.e., *bla*<sub>DIM-1</sub>, *bla*<sub>NDM-1</sub>, and/or *bla*<sub>VIM-2</sub>; and four had genes encoding other  $\beta$ -lactamases, i.e., *bla*<sub>PDCs</sub>, *bla*<sub>PSE-2</sub>, *bla*<sub>TEM-1</sub>, or *bla*<sub>VEB-1a</sub> (Table 1). In addition, 5 isolates had a 16S rRNA methyltransferase encoding gene, *rmtB4* or *rmtF2*; and nine had genes encoding an aminoglycoside acetyl- and adenyltransferase, including AAC(6')-Ib, AACA7, AAC5b, and AADB (Table 1). A novel *rmtF2* gene was located in the class 1 integron (Fig. 1). All isolates except for IOMTU3 had amino acid substitution point mutations S83I in GyrA and S80L in ParC; IOMTU3 had amino acid substitution point mutations S83L and D87E in GyrA and S80L in ParC.

A total of 6 isolates were classified as ST664, two as ST235, and one each as ST244, ST654, and ST1047. The two ST235 isolates harbored *bla*<sub>NDM-1</sub>, *bla*<sub>VIM-2</sub>, and *rmtB4*; two of the ST664 isolates harbored *rmtF2*; the ST654 isolate harbored *bla*<sub>VIM-2</sub>; and the ST1047 isolate harbored *bla*<sub>DIM-1</sub> and *rmtF2*.

Because IOMTU133 belonged to ST1047 and harbored several drug resistance genes, its complete genome was sequenced and deposited in GenBank under accession no. AP017302. This isolate had no plasmids. The complete genome sequence of IOMTU133 had 283-fold coverage for one chromosome, IOMTU133, which consisted of a single circular chromosome of 6,897,018 bp with an average GC content of 65.98%. The chromosome was found to contain 6,245 protein-encoding genes, including 63 tRNA genes and one transfer messenger RNA (tmRNA) gene for all amino acids. IOMTU133 also harbored a carbapenemase-encoding gene, *bla*<sub>DIM-1</sub>; a 16S rRNA methyltransferase encoding gene, *rmtF2*; and an aminoglycoside acetyltransferase encoding gene, *aac(6')-Ib*. The *bla*<sub>DIM-1</sub> gene and a novel *rmtF2* gene were located within the same integron on the chromosome (Fig. 1).

The genomic environments surrounding *bla*<sub>DIM-1</sub>, *bla*<sub>NDM-1</sub>, *bla*<sub>VIM-2</sub>, *rmtB4*, and *rmtF2* are shown in Fig. 1. The genomic environments of *bla*<sub>DIM-1</sub>, *bla*<sub>NDM-1</sub>, and *bla*<sub>VIM-2</sub> were *IS6-int11-bla*<sub>DIM-1</sub>-*dfr2e-aac(6')-Ib-rmtF2-insE-cat-orf1* (gene encoding a hypothetical protein)-*IS6* (accession no. AP017302), *tnp-bla*<sub>NDM-1</sub>-*orf2* (gene encoding a hypothetical protein) (accession no. LC054839), and *int11-aadB-aacA7-bla*<sub>VIM-2</sub>-*dhfrB5-aacA5-tniR-tniQ-tniB-tniA* (accession no. LC054840), respectively. The genomic environments surrounding these carbapenemase-encoding genes were unique to these isolates.

The genomic environment of *rmtB4* was *tnp-groEL-orf3* (gene encoding queuine tRNA-ribosyltransferase)-*orf4* (gene encoding a hypothetical protein)-*rmtB4-orf5* (gene encoding a putative Na<sup>+</sup>/H<sup>+</sup> antiporter) (accession no. LC052325), whereas the

**TABLE 1** Summary of characteristics of the 11 *Pseudomonas aeruginosa* strains, including antimicrobial resistance profiles and resistant genes

Strain	MICs ( $\mu\text{g/ml}$ ) for <sup>a</sup> :							16S rRNA methylase	Aminoglycoside acetyl/adenylyltransferase(s)	Mutation(s) in DNA gyrase			
	MLST	IPM	MEM	ATM	CAZ	AMK	ABK				CIP	CST	$\beta$ -Lactamase(s)
IOMTU 3	654	128	32	16	128	128	1	256	$\leq 0.5$	VIM-2, PDC-58	AADB	S83L, D87E	S80L
IOMTU 7	244	16	32	>1024	>1024	32	16	32	$\leq 0.5$	VEB-Ia, PDC-61	AAC(6')-Ib	S83I	S80L
IOMTU 9	235	512	>1024	32	>1024	>1024	>1024	64	$\leq 0.5$	NDM-1, VIM-2, PDC-35	AACA7, AACCS5b	S83I	S80L
IOMTU 133	1047	32	64	16	256	>1024	>1024	32	$\leq 0.5$	DIM-1, PDC-32	AAC(6')-Ib	S83I	S80L
IOMTU 141	664	1	4	16	8	128	1	32	$\leq 0.5$	PDC-98	AAC(6')-Ib	S83I	S80L
IOMTU 155	664	1	4	32	8	128	1	32	$\leq 0.5$	PDC-98	AAC(6')-Ib	S83I	S80L
IOMTU 161	664	1	4	16	8	128	1	32	$\leq 0.5$	PCD-98	AAC(6')-Ib	S83I	S80L
IOMTU 179	664	1	4	32	4	128	1	32	$\leq 0.5$	TEM-1, PDC-98	AAC(6')-Ib	S83I	S80L
IOMTU 184	664	8	32	128	>1024	>1024	>1024	64	$\leq 0.5$	PSE-2, PDC-98	AAC(6')-Ib	S83I	S80L
IOMTU 304	235	512	>1024	32	>1024	>1024	>1024	64	$\leq 0.5$	NDM-1, VIM-2, PDC-35	AACA7, AACCS5b	S83I	S80L
IOMTU 487	664	2	32	128	512	>1024	>1024	32	$\leq 0.5$	PSE-2, PDC-98	AADB	S83I	S80L

<sup>a</sup>IPM, imipenem; MEM, meropenem; ATM, aztreonam; CAZ, ceftazidime; AMK, amikacin; ABK, arbekacin; CIP, ciprofloxacin; CST, colistin.

Downloaded from <http://aac.asm.org/> on December 25, 2017 by Kohnodai Hospital, National Center for Global Health and Medicine

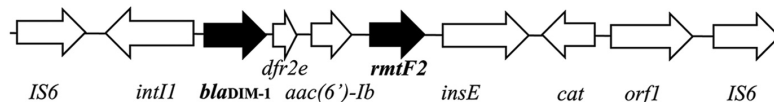
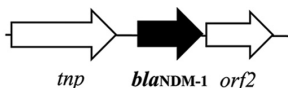
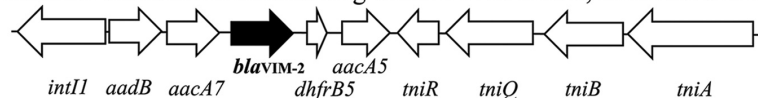
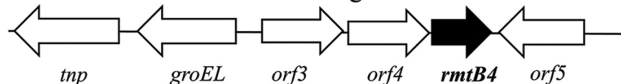
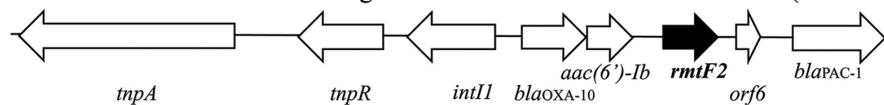
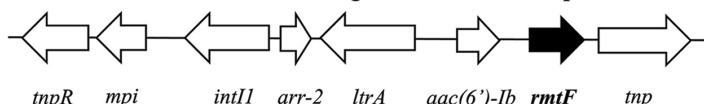
Genomic environment surrounding *bla*<sub>DIM-1</sub> in IOMTU133 (accession no. AP017302)Genomic environment surrounding *bla*<sub>NDM-1</sub> in IOMTU9 and IOMTU304 (accession no. LC054839)Genomic environment surrounding *bla*<sub>VIM-2</sub> in IOMTU3, IOMTU9 and IOMTU304 (accession no. LC054840)Genomic environment surrounding *rmtB4* in IOMTU9 and IOMTU304 (accession no. LC052325)Genomic environment surrounding *rmtF2* in IOMTU 184 and IOMTU487 (accession no. LC224309)Genomic environment surrounding *rmtF* in *Klebsiella pneumoniae* UCLAOXA232KP (accession no. CP012569)

**FIG 1** Genomic environment surrounding *bla*<sub>DIM-1</sub> in IOMTU133 (accession no. AP017302); *bla*<sub>NDM-1</sub> in IOMTU9 and IOMTU304 (accession no. LC054839); *bla*<sub>VIM-2</sub> in IOMTU3, IOMTU9 and IOMTU304 (accession no. LC054840); *rmtB4* in IOMTU9 and IOMTU304 (accession no. LC052325); *rmtF2* in IOMTU184 and IOMTU487 (accession no. LC224309); and *rmtF* in *Klebsiella pneumoniae* UCLAOXA232KP (accession no. CP012569).

genomic environment of *rmtF2* was *tnpA-tnpR-intI1-bla*<sub>OXA-10</sub>-*aac(6')-Ib-rmtF2-orf6* (gene encoding a hypothetical protein)-*bla*<sub>PAC-1</sub> (accession no. LC224309). The *rmtF2* in IOMTU133 was located in the same integron as *bla*<sub>DIM-1</sub> (Fig. 1). Compared to the genomic environment surrounding *rmtF* in *K. pneumoniae* UCLAOXA232KP plasmid pUCLAOXA232-3.X (accession no. CP012569), both *rmtF* and *rmtF2* were located in class I integron, which contained *aac(6')-Ib* in the upstream regions of *rmtF* and *rmtF2*; however, the other allelic profiles in each integron were different (Fig. 1). The genomic environments surrounding *rmtB4* and *rmtF2* were unique to these isolates.

Of all the isolates tested, only IOMTU487 had a 120-kbp plasmid, but the plasmid did not harbor the *bla*<sub>DIM-1</sub>, *bla*<sub>NDM-1</sub>, *bla*<sub>VIM-2</sub>, *rmtB4*, or *rmtF2* genes (see Fig. S1 in the supplemental material). All of these genes were located in the chromosomes (see Fig. S2 in the supplemental material).

The findings of this study indicate that ST664 *P. aeruginosa* clinical isolates spread in a medical setting in Nepal, because the majority of *P. aeruginosa* isolates obtained in Nepal were classified as ST664. To date, seven ST664 isolates (PubMLST no. 3401, 3707, 4018, 4033, 4052, 4060, and 4787) have been registered on the PubMLST website (<https://pubmlst.org/paeruginosa/>). Of these, PubMLST no. 4787 (*Pseudomonas aeruginosa* VRFPA06) was isolated from human blood in 2012 in India (17), although the details of others were not reported. Of our 11 isolates, only two were classified as ST235,

which has been recognized as one of three high-risk clones, i.e., ST235, ST111, and ST175 (18). A *P. aeruginosa* strain belonging to ST1047, which was originally obtained in Norway and found to produce VIM-type MBLs, was first registered on the PubMLST website in 2011 (PubMLST no. 746).

This is the first report describing carbapenemase- and 16S rRNA methyltransferase-coproducing *P. aeruginosa* clinical isolates in Nepal. Carbapenemase- and 16S rRNA methyltransferase-coproducing *P. aeruginosa* was reported in 2007 in Brazil (19) and in 2015 in northeast India (20), which is bordered by Nepal. It is therefore necessary to survey multidrug-resistant *P. aeruginosa* in medical settings in Nepal.

**Accession number(s).** The sequences described were submitted to GenBank under the accession numbers LC050387, LC052325, LC054839, LC054840, LC224309, and AP017302.

#### SUPPLEMENTAL MATERIAL

Supplemental material for this article may be found at <https://doi.org/10.1128/AAC.00694-17>.

**SUPPLEMENTAL FILE 1**, PDF file, 0.1 MB.

#### ACKNOWLEDGMENTS

This study was reviewed and approved by the Institutional Review Board of the Institute of Medicine at Tribhuvan University (reference no. 6-11-E) and the Biosafety Committee at the National Center for Global Health and Medicine (approval no. 28-M-053). The study was supported by grants from International Health Cooperation Research (grant 29-S-5), the Okinawa Communicable Disease Research Hub Formation Promotion Project, Okinawa Prefectural Government Commissioned Projects For Fiscal Year 2016, the Research Program on Emerging and Re-emerging Infectious Diseases from Japan Agency for Medical Research and Development (AMED), and JSPS KAKENHI (grant 16K19133).

#### REFERENCES

- Bush K. 2001. New  $\beta$ -lactamases in gram-negative bacteria: diversity and impact on the selection of antimicrobial therapy. *Clin Infect Dis* 32:1085–1089. <https://doi.org/10.1086/319610>.
- Poirer L, Rodriguez-Martinez JM, Al Naiemi N, Debets-Ossenkopp YJ, Nordmann P. 2010. Characterization of DIM-1, an integron-encoded metallo- $\beta$ -lactamase from a *Pseudomonas stutzeri* clinical isolate in the Netherlands. *Antimicrob Agents Chemother* 54:2420–2424. <https://doi.org/10.1128/AAC.01456-09>.
- Deshpande LM, Jones RN, Woosley LN, Castanheira M. 2014. Retrospective molecular analysis of DIM-1 metallo- $\beta$ -lactamase discovered in *Pseudomonas stutzeri* from India in 2000. *Antimicrob Agents Chemother* 58:596–598. <https://doi.org/10.1128/AAC.01541-13>.
- Leski TA, Bangura U, Jimmy DH, Ansumana R, Lizewski SE, Li RW, Stenger DA, Taitt CR, Vora GJ. 2013. Identification of *bla*<sub>OXA-51-like</sub>, *bla*<sub>OXA-58</sub>, *bla*<sub>DIM-1</sub>, and *bla*<sub>VIM</sub> carbapenemase genes in hospital *Enterobacteriaceae* isolates from Sierra Leone. *J Clin Microbiol* 51:2435–2438. <https://doi.org/10.1128/JCM.00832-13>.
- Wachino J, Yamane K, Shibayama K, Kurokawa H, Shibata N, Suzuki S, Doi Y, Kimura K, Ike Y, Arakawa Y. 2006. Novel plasmid-mediated 16S rRNA methylase, RmtC, found in a *Proteus mirabilis* isolate demonstrating extraordinary high-level resistance against various aminoglycosides. *Antimicrob Agents Chemother* 50:178–184. <https://doi.org/10.1128/AAC.50.1.178-184.2006>.
- Wachino J, Arakawa Y. 2012. Exogenously acquired 16S rRNA methyltransferases found in aminoglycoside-resistant pathogenic Gram-negative bacteria: an update. *Drug Resist Updat* 15:133–148. <https://doi.org/10.1016/j.drug.2012.05.001>.
- Galimand M, Courvalin P, Lambert T. 2012. RmtF, a new member of the aminoglycoside resistance 16S rRNA N7 G1405 methyltransferase family. *Antimicrob Agents Chemother* 56:3960–3962. <https://doi.org/10.1128/AAC.00660-12>.
- Bueno MF, Francisco GR, O'Hara JA, de Oliveira Garcia D, Doi Y. 2013. Co-production of 16S ribosomal RNA methyltransferase RmtD and RmtG with KPC-2 and CTX-M-group extended-spectrum  $\beta$ -lactamases in *Klebsiella pneumoniae*. *Antimicrob Agents Chemother* 57:2397–2400. <https://doi.org/10.1128/AAC.02108-12>.
- O'Hara JA, McGann P, Snesrud EC, Clifford RJ, Waterman PE, Lesho EP, Doi Y. 2013. Novel 16S ribosomal RNA methyltransferase RmtH produced by *Klebsiella pneumoniae* associated with war-related trauma. *Antimicrob Agents Chemother* 57:2413–2416. <https://doi.org/10.1128/AAC.00266-13>.
- Hidalgo L, Hopkins KL, Gutierrez B, Ovejero CM, Shukla S, Douthwaite S, Prasad KN, Woodford N, Gonzalez-Zorn B. 2013. Association of the novel aminoglycoside resistance determinant RmtF with NDM carbapenemase in *Enterobacteriaceae* isolated in India and the UK. *J Antimicrob Chemother* 68:1543–1550. <https://doi.org/10.1093/jac/dkt078>.
- Tada T, Miyoshi-Akiyama T, Dahal RK, Mishra SK, Ohara H, Shimada K, Kirikae T, Pokhrel BM. 2013. Dissemination of multidrug-resistant *Klebsiella pneumoniae* clinical isolates with various combinations of carbapenemases (NDM-1 and OXA-72) and 16S rRNA methylases (ArmA, RmtC and RmtF) in Nepal. *Int J Antimicrob Agents* 42:372–374. <https://doi.org/10.1016/j.ijantimicag.2013.06.014>.
- Kirikae T, Mizuguchi Y, Arakawa Y. 2008. Investigation of isolation rates of *Pseudomonas aeruginosa* with and without multidrug resistance in medical facilities and clinical laboratories in Japan. *J Antimicrob Chemother* 61:612–615. <https://doi.org/10.1093/jac/dkm537>.
- Clinical and Laboratory Standards Institute. 2015. Performance standards for antimicrobial susceptibility testing; 25th informational supplement. CLSI M100-S25. Clinical and Laboratory Standards Institute, Wayne, PA.
- Tada T, Miyoshi-Akiyama T, Shimada K, Shiroma A, Nakano K, Teruya K, Satou K, Hirano T, Shimojima M, Kirikae T. 2016. A carbapenem-resistant *Pseudomonas aeruginosa* isolate harboring two copies of *bla*<sub>IMP-34</sub> encoding a metallo- $\beta$ -lactamase. *PLoS One* 11:e0149385. <https://doi.org/10.1371/journal.pone.0149385>.
- Wachino J, Yoshida H, Yamane K, Suzuki S, Matsui M, Yamagishi T, Tsutsui A, Konda T, Shibayama K, Arakawa Y. 2011. SMB-1, a novel subclass B3 metallo- $\beta$ -lactamase, associated with ISCR1 and a class 1

Tada et al.

Antimicrobial Agents and Chemotherapy

- integron, from a carbapenem-resistant *Serratia marcescens* clinical isolate. *Antimicrob Agents Chemother* 55:5143–5149. <https://doi.org/10.1128/AAC.05045-11>.
16. Tada T, Miyoshi-Akiyama T, Shimada K, Kirikae T. 2014. Biochemical analysis of metallo- $\beta$ -lactamase NDM-3 from a multidrug-resistant *Escherichia coli* strain isolated in Japan. *Antimicrob Agents Chemother* 58: 3538–3540. <https://doi.org/10.1128/AAC.02793-13>.
  17. Murugan N, Malathi J, Umashankar V, Madhavan HN. 2014. Comparative genomic analysis of multidrug-resistant *Pseudomonas aeruginosa* clinical isolates VRFPA06 and VRFPA08 with VRFPA07. *Genome Announc* 2:e00140-14. <https://doi.org/10.1128/genomeA.00140-14>.
  18. Oliver A, Mulet X, Lopez-Causape C, Juan C. 2015. The increasing threat of *Pseudomonas aeruginosa* high-risk clones. *Drug Resist Updat* 21: 41–59. <https://doi.org/10.1016/j.drug.2015.08.002>.
  19. Doi Y, de Oliveira Garcia D, Adams J, Paterson DL. 2007. Coproduction of novel 16S rRNA methylase RmtD and metallo- $\beta$ -lactamase SPM-1 in a panresistant *Pseudomonas aeruginosa* isolate from Brazil. *Antimicrob Agents Chemother* 51:852–856. <https://doi.org/10.1128/AAC.01345-06>.
  20. Rahman M, Prasad KN, Pathak A, Pati BK, Singh A, Ovejero CM, Ahmad S, Gonzalez-Zorn B. 2015. RmtC and RmtF 16S rRNA methyltransferase in NDM-1-producing *Pseudomonas aeruginosa*. *Emerg Infect Dis* 21: 2059–2062. <https://doi.org/10.3201/eid2111.150271>.

Downloaded from <http://aac.asm.org/> on December 25, 2017 by Kohnodai Hospital, National Center for Global Health and Medicine

AMERICAN  
SOCIETY FOR  
MICROBIOLOGYAntimicrobial Agents  
and Chemotherapy®

EPIDEMIOLOGY AND SURVEILLANCE

Downloaded from <http://aac.asm.org/> on December 25, 2017 by Kohnodai Hospital, National Center for Global Health and Medicine

## Emergence of Various NDM-Type-Metallo- $\beta$ -Lactamase-Producing *Escherichia coli* Clinical Isolates in Nepal

Basudha Shrestha,<sup>a</sup> Tatsuya Tada,<sup>b,c</sup> Kayo Shimada,<sup>c</sup> Shovita Shrestha,<sup>a</sup> Hiroshi Ohara,<sup>d</sup> Bharat Mani Pokhrel,<sup>a</sup> Jeevan B. Sherchand,<sup>a</sup> Teruo Kirikae<sup>b,c</sup>

Department of Microbiology, Institute of Medicine, Tribhuvan University, Kathmandu, Nepal<sup>a</sup>; Department of Microbiology, Juntendo University School of Medicine, Tokyo, Japan<sup>b</sup>; Department of Infectious Diseases, Research Institute, National Center for Global Health and Medicine, Tokyo, Japan<sup>c</sup>; Bureau of International Medical Cooperation, National Center for Global Health and Medicine, Tokyo, Japan<sup>d</sup>

**ABSTRACT** Of 250 clinical isolates of *Escherichia coli* obtained in Nepal, 38 were carbapenem resistant, with MICs of imipenem or meropenem of  $\geq 4$   $\mu\text{g/ml}$ . All 38 isolates harbored the following *bla*<sub>NDM</sub>S: *bla*<sub>NDM-1</sub>, *bla*<sub>NDM-3</sub>, *bla*<sub>NDM-4</sub>, *bla*<sub>NDM-5</sub>, *bla*<sub>NDM-7</sub>, *bla*<sub>NDM-12</sub>, and *bla*<sub>NDM-13</sub>. Most of these isolates also harbored the 16S rRNA methylase gene(s) *armA*, *rmtB*, and/or *rmtC*.

**KEYWORDS** NDM-type metallo- $\beta$ -lactamase, carbapenem-resistant *Escherichia coli*, molecular epidemiology

**M**etallo- $\beta$ -lactamases (MBLs) can confer resistance to carbapenems, reducing their susceptibility to carbapenems, as well as to cephalosporins and penicillins but not to monobactams (1). New Delhi metallo- $\beta$ -lactamase-1 (NDM-1) was initially isolated in 2008 from *Klebsiella pneumoniae* and *Escherichia coli* strains originating in India (2). To date, 16 NDM variants have been identified (<ftp://ftp.ncbi.nlm.nih.gov/pathogen/betalactamases/Allele.tab>). Since the initial observation, NDM-producing *Enterobacteriaceae* strains have been isolated in various parts of the world, including Australia, Bangladesh, Belgium, Canada, France, India, Kenya, Japan, Nepal, the Netherlands, New Zealand, Pakistan, Singapore, Taiwan, and the United States (3–6). This study analyzed the molecular epidemiology of carbapenem-resistant *E. coli* isolates obtained from a university hospital in Nepal.

A total of 250 consecutive nonrepetitive clinical isolates of *E. coli* were obtained from 250 patients hospitalized between December 2013 and December 2014 at a university hospital in Kathmandu, Nepal. These bacterial isolates were collected from urine ( $n = 92$ ), pus ( $n = 65$ ), sputum ( $n = 36$ ), catheter specimens ( $n = 35$ ), blood ( $n = 9$ ), bile ( $n = 5$ ), body fluid ( $n = 4$ ), and other specimens ( $n = 4$ ). Species identification was confirmed by 16S rRNA sequencing (7). Antimicrobial susceptibility to amikacin, arbekacin, ceftazidime, ciprofloxacin, colistin, imipenem, meropenem, and tigecycline was tested by the microdilution method according to the guidelines of the Clinical and Laboratory Standards Institute (8). Carbapenem-resistant *E. coli* isolates were defined as having imipenem or meropenem MICs of  $\geq 4$   $\mu\text{g/ml}$ . The whole genomes of all carbapenem-resistant *E. coli* isolates were extracted using DNeasy blood and tissue kits (Qiagen, Tokyo, Japan) and sequenced with a MiSeq sequencer (Illumina, San Diego, CA). The raw reads were assembled using CLC Genomics Workbench version 8.0.2 (CLC bio, Tokyo, Japan). A summary of the assembly is shown in Table S1 in the supplemental material. The whole-genome sequences of all 38 isolates were deposited in GenBank as accession no. DRA005225. To analyze the relationships among these 38 *E. coli* isolates, the complete genome of an *E. coli* sequence type 2747 (ST2747) strain (GenBank accession no. CP007394) was used as a reference, because a BLAST search showed that

Received 13 July 2017 Returned for modification 2 August 2017 Accepted 30 September 2017

Accepted manuscript posted online 9 October 2017

**Citation** Shrestha B, Tada T, Shimada K, Shrestha S, Ohara H, Pokhrel BM, Sherchand JB, Kirikae T. 2017. Emergence of various NDM-type-metallo- $\beta$ -lactamase-producing *Escherichia coli* clinical isolates in Nepal. *Antimicrob Agents Chemother* 61:e01425-17. <https://doi.org/10.1128/AAC.01425-17>.

**Copyright** © 2017 American Society for Microbiology. All Rights Reserved.

Address correspondence to Tatsuya Tada, [t-tada@juntendo.ac.jp](mailto:t-tada@juntendo.ac.jp).



**TABLE 1** MIC<sub>90</sub> and MIC<sub>50</sub> values and percentages of antimicrobial resistance among *E. coli* clinical isolates<sup>a</sup>

Antimicrobial agent	Breakpoint for resistance (μg/ml)	% of strains resistant	MIC (μg/ml)		
			Range	MIC <sub>50</sub>	MIC <sub>90</sub>
Amikacin	≥64	87	2->512	>512	>512
Arbekacin			1->512	>512	>512
Ceftazidime	≥16	100	512->512	>512	>512
Ciprofloxacin	≥4	100	8->256	128	>512
Colistin	≥4	0	≤0.125-1	0.125	1
Imipenem	≥4	100	4-256	16	64
Meropenem	≥4	100	8-128	32	64
Tigecycline	≥4	5	≤0.125-4	2	2

<sup>a</sup>Thirty-eight isolates were tested. Breakpoints for antimicrobial resistance were determined according to guidelines of the Clinical and Laboratory Standards Institute. The breakpoint for tigecycline resistance was provided for *Enterobacteriaceae* by EUCAST and the U.S. Food and Drug Administration (FDA).

this strain was genetically close to the isolates tested ([https://blast.ncbi.nlm.nih.gov/Blast.cgi?PROGRAM=blastn&PAGE\\_TYPE=BlastSearch&LINK\\_LOC=blasthome](https://blast.ncbi.nlm.nih.gov/Blast.cgi?PROGRAM=blastn&PAGE_TYPE=BlastSearch&LINK_LOC=blasthome)). Concatenated single nucleotide polymorphism (SNP) sequences were aligned by MAFFT (<http://mafft.cbrc.jp/alignment/server/>). Models and parameters used for the phylogenetic analyses were computed using jModelTest 2.1.4. A maximum-likelihood phylogenetic tree was constructed from SNP alignment with PhyML 3.0 (9). The sequences of drug resistance genes, including β-lactamase-encoding genes, aminoglycoside resistance genes, and quinolone resistance genes, were determined using ResFinder 2.1 (<https://cge.cbs.dtu.dk/services/ResFinder/>). Multilocus sequence types (MLSTs) were deduced as described in the protocols of the University of Warwick MLST databases (<http://mlst.warwick.ac.uk/mlst/dbs/Ecoli>), and clonal complexes (CC) were determined by eBURST version 3 (<http://eburst.mlst.net>). To determine the sizes of the plasmids harboring *bla*<sub>NDM</sub>s, plasmid DNAs in each isolate were extracted and digested with S1 nuclease. Pulsed-field gel electrophoresis (PFGE) and Southern hybridization were performed (10).

Of the 250 *E. coli* isolates, 38 were carbapenem resistant; 9 of these were from respiratory tracts, 10 were from pus and wounds, 18 were from urinary tracts, and 1 was from other sources. According to CLSI guidelines (11), 33 (87%) of the 38 isolates were multidrug resistant (Table 1). All isolates were resistant to ceftazidime, ciprofloxacin, and meropenem, but they were susceptible to colistin. Thirty-six isolates (95%) were sensitive to tigecycline (MICs of ≤1 μg/ml), whereas for two isolates (5%), the MICs were 4 μg/ml. The 38 carbapenem-resistant *E. coli* isolates belonged to 11 different MLSTs: ST38 (3 isolates), ST94 (1 isolate), ST101 (6 isolates), ST167 (5 isolates), ST361 (2 isolates), ST405 (8 isolates), ST448 (3 isolates), ST648 (5 isolates), ST2083 (2 isolates), ST2659 (1 isolate), and ST4108 (2 isolates) (Table 2). eBURST analysis revealed that the ST38 and ST2659 isolates belonged to CC38 and that ST94, ST448, and ST2083 isolates belonged to CC94. A maximum-likelihood phylogenetic tree constructed from the 38 carbapenem-resistant *E. coli* isolates revealed three clades (Fig. 1). Clade A consisted of the isolates belonging to ST38, ST405, ST2659, and ST2747 (an *E. coli* ST2747 strain was the reference strain). Clade B comprised the isolates belonging to ST94, ST101, ST167, ST361, ST448, ST2083, and ST4108. Clade C had one isolate belonging to ST648. Clade A contained subclade CC38, which consisted of the isolates belonging to ST38 and ST2659, and clade B contained subclade CC94, which consisted of the isolates belonging to ST94, ST448, and ST2083. All 38 carbapenem-resistant *E. coli* isolates harbored *bla*<sub>NDM</sub>s, with 16, 11, 7, 1, 1, 1, and 1 harboring *bla*<sub>NDM-1</sub>, *bla*<sub>NDM-5</sub>, *bla*<sub>NDM-7</sub>, *bla*<sub>NDM-3'</sub>, *bla*<sub>NDM-4'</sub>, *bla*<sub>NDM-12'</sub>, and *bla*<sub>NDM-13'</sub>, respectively (Table 2). In addition, 30 isolates, 29 isolates, 1 isolate, and 1 isolate harbored *bla*<sub>CTX-M-15'</sub>, *bla*<sub>TEM-1'</sub>, *bla*<sub>TEM-166'</sub>, and *bla*<sub>OXA-181'</sub>, respectively (Table S2).

Of the 38 isolates, 33 (87%) harbored 16S rRNA methylase-encoding genes, including 14, 11, and 4 harboring *armA*, *rmtB*, and *rmtC*, respectively; 2 harboring both *armA* and *rmtB*; 2 harboring both *armA* and *rmtC*; and 30 harboring *aac(6')-Ib-cr* (Table S2).

**TABLE 2** Summary of the characteristics of the 38 carbapenem-resistant *E. coli* strains, including MLSTs and drug resistance genes<sup>a</sup>

MLST	No. of isolates	Clonal complex	Carbapenemase- and extended-spectrum $\beta$ -lactamase-encoding gene(s)	16S rRNA methylase- and aminoglycoside acetyltransferase-encoding genes	Mutation(s) in DNA gyrase		
					GyrA	ParC	ParE
ST38	3	CC38	<i>bla</i> <sub>NDM-1</sub> (2/3), <i>bla</i> <sub>NDM-3</sub> (1/3), <i>bla</i> <sub>CTX-M-15</sub>	<i>rmtC</i> , <i>aac(6')-1b-cr</i> , <i>aac(3)-IIa</i> (1/3), <i>aadA1</i>	S83L, D87N	S80I, E84G	
ST94	1	CC94	<i>bla</i> <sub>NDM-1</sub>	<i>armA</i> , <i>aac(6')-1b-cr</i> , <i>aadA1</i> , <i>aadA2</i>	S83L, D87N	S80I	
ST101	6		<i>bla</i> <sub>NDM-1</sub> (3/6), <i>bla</i> <sub>NDM-5</sub> (1/6), <i>bla</i> <sub>NDM-7</sub> (1/6), <i>bla</i> <sub>NDM-13</sub> (1/6), <i>bla</i> <sub>CTX-M-15</sub> (5/6), <i>bla</i> <sub>TEM-166</sub> (1/6)	<i>armA</i> (2/6), <i>armA</i> and <i>rmtB</i> (2/6), <i>rmtB</i> (1/6), <i>aac(6')-1b-cr</i> , <i>aadA1</i> (3/6), <i>aadA2</i> (2/6)	S83L, D87N	S80I	E455D
ST167	5		<i>bla</i> <sub>NDM-5</sub> , <i>bla</i> <sub>CTX-M-15</sub> (4/5), <i>bla</i> <sub>OXA-181</sub> (1/5)	<i>rmtB</i> , <i>aac(6')-1b-cr</i> (2/5), <i>aadA1</i> (1/5), <i>aadA2</i> (3/5), <i>aadA5</i> (1/5)	S83L, D87N	S80I	
ST361	2		<i>bla</i> <sub>NDM-1</sub> (1/2), <i>bla</i> <sub>NDM-5</sub> (1/2), <i>bla</i> <sub>CTX-M-15</sub>	<i>rmtB</i> (1/2), <i>rmtC</i> (1/2), <i>aac(6')-1b</i> (1/2), <i>aadA1</i> , <i>aadA2</i> (1/2), <i>aphA6</i> (1/2)	S83L, D87N	S80I	
ST405	8		<i>bla</i> <sub>NDM-1</sub> (4/8), <i>bla</i> <sub>NDM-4</sub> (1/8), <i>bla</i> <sub>NDM-5</sub> (2/8), <i>bla</i> <sub>NDM-7</sub> (1/8), <i>bla</i> <sub>CTX-M-15</sub> (7/8)	<i>armA</i> (4/8), <i>armA</i> and <i>rmtC</i> (1/8), <i>rmtB</i> (2/8), <i>aac(6')-1b-cr</i> (6/8), <i>aadA2</i> , <i>aphA6</i> (2/8), <i>aac(3)-IIa</i> (1/8)	S83L, D87N	S80I	
ST448	3	CC94	<i>bla</i> <sub>NDM-1</sub> (1/3), <i>bla</i> <sub>NDM-5</sub> (1/3), <i>bla</i> <sub>NDM-12</sub> (1/3), <i>bla</i> <sub>CTX-M-15</sub> (1/3)	<i>armA</i> (1/3), <i>rmtB</i> (1/3), <i>aac(6')-1b-cr</i> , <i>aac(3)-IIa</i> (1/3), <i>aadA1</i> (1/3), <i>aadA2</i> (1/3)	S83L, D87N	S80I, E84G	
ST648	5		<i>bla</i> <sub>NDM-1</sub> (1/5), <i>bla</i> <sub>NDM-5</sub> (1/5), <i>bla</i> <sub>NDM-7</sub> (3/5), <i>bla</i> <sub>CTX-M-15</sub> (4/5)	<i>armA</i> (2/5), <i>armA</i> and <i>rmtC</i> (1/5), <i>rmtB</i> (1/5), <i>aac(6')-1b-cr</i> (4/5), <i>aadA1</i> (1/5), <i>aadA2</i> (4/5)	S83L, D87N	S80I	
ST2083	2	CC94	<i>bla</i> <sub>NDM-1</sub> , <i>bla</i> <sub>CTX-M-15</sub> (1/2)	<i>armA</i> , <i>aac(6')-1b-cr</i> , <i>aadA1</i> , <i>aadA2</i>	S83L, D87N	S80I	
ST2659	1	CC38	<i>bla</i> <sub>NDM-1</sub> , <i>bla</i> <sub>CTX-M-15</sub>	<i>rmtC</i> , <i>aac(6')-1b-cr</i>	S83L, D87N	S80I	
ST4108	2		<i>bla</i> <sub>NDM-7</sub> , <i>bla</i> <sub>CTX-M-15</sub>	<i>armA</i> , <i>aac(6')-1b-cr</i> , <i>aadA1</i> , <i>aadA2</i>	S83L, D87N	S80I	

<sup>a</sup>Numbers in parentheses are the number of isolates with the named gene/number tested.

Sequences derived from each contig datum after assembly of the raw read data showed that 16 types of genetic structures surrounded *bla*<sub>NDM5</sub> (Fig. 2). Of the 16 isolates harboring *bla*<sub>NDM-1</sub>, 7 were type B, 5 were type A, and 1 each was type C, D, E, or F. The genomic environment surrounding *bla*<sub>NDM-3</sub> was *tnpA bla*<sub>NDM-3 ble</sub><sub>MBL trpF</sub>

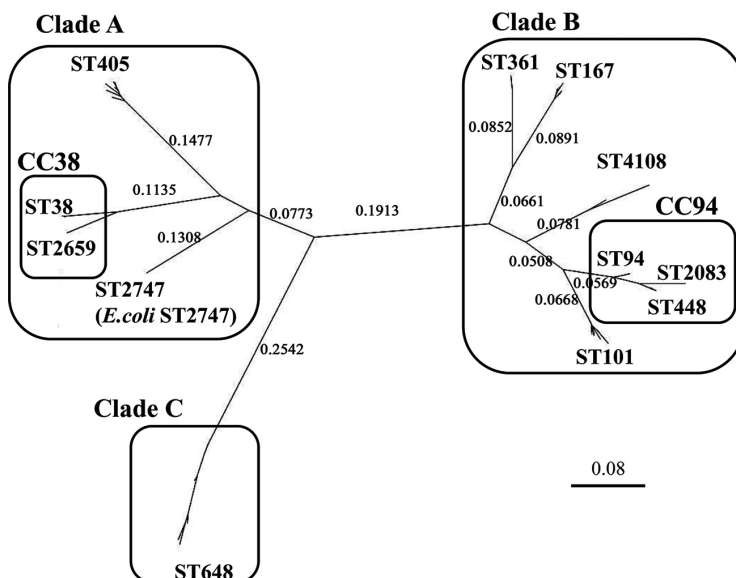

**FIG 1** Molecular phylogeny of the 38 *E. coli* strains. A maximum-likelihood phylogenetic tree constructed from the 38 carbapenem-resistant isolates revealed three clades. The length of the concatemer was 244,995 bp. Clade A consisted of the isolates belonging to ST38, ST405, ST2659, and ST2747 (*E. coli* ST2747 was the reference strain). Clade B consisted of the isolates belonging to ST94, ST101, ST167, ST361, ST448, ST2083, and ST4108. Clade C consisted of only one isolate, and it belonged to ST648. Clade A contained subclade CC38, consisting of isolates belonging to ST38 and ST2659, and clade B contained subclade CC94, consisting of isolates belonging to ST94, ST448, and ST2083.

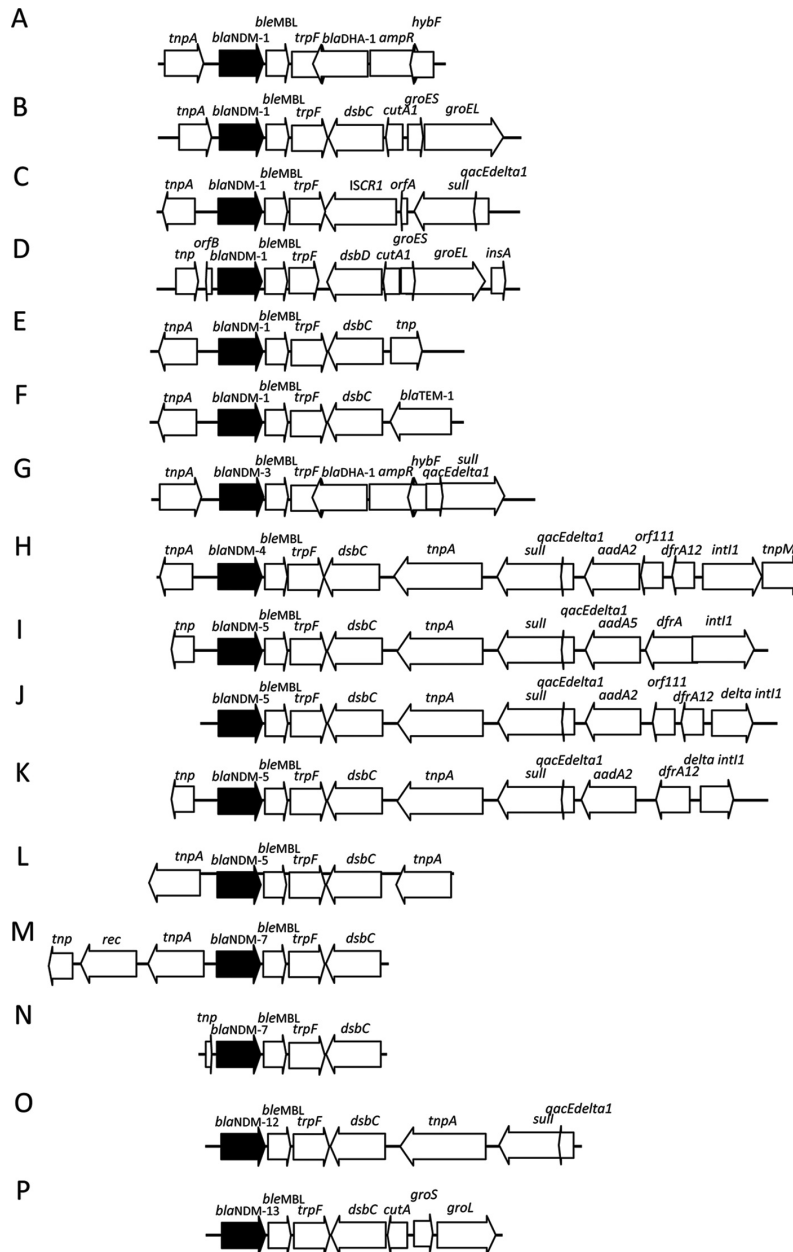

**FIG 2** Structures of the genomic environments, including of *bla*<sub>NDM-1</sub> (A to F), *bla*<sub>NDM-3</sub> (G), *bla*<sub>NDM-4</sub> (H), *bla*<sub>NDM-5</sub> (I to L), *bla*<sub>NDM-7</sub> (M and N), *bla*<sub>NDM-12</sub> (O), and *bla*<sub>NDM-13</sub> (P), from sequences from each contig datum after assembling. *orfA* and *orfB*, hypothetical protein-encoding genes.

*bla*<sub>DHA-1</sub> *ampR* *hybF* *qacEdelta1* *sull* (type G in Fig. 2). This sequence showed greater than 99.9% identity with that in NDM-3-producing *E. coli* EC2 plasmid pEC2-NDM-3 in Australia (12). The genomic environment surrounding *bla*<sub>NDM-4</sub> was *tnpA* *bla*<sub>NDM-4</sub> *ble*<sub>MBL</sub> *trpF* *dsbC* *tnpA* *sul1* *qacEdelta1* *aadA2* *orf111* *dfrA12* *int1* *tnpM* (type H in Fig. 2). This sequence had more than 99.9% identity with that in NDM-1-producing *E. coli* GUE plasmid pGUE-NDM in India (13). The genomic environments surrounding *bla*<sub>NDM-5</sub> had

4 types of structures: types I, J, K, and L (Fig. 2). Of 11 NDM-5 producers, 6 were type I, 3 were type J, and 2 each were type K or L. The genomic environment surrounding *bla*<sub>NDM-7</sub> had two types of structures, M and N (Fig. 2). The structure in type M was unique, whereas the structure in type N was identical to that in the NDM-7-producing *E. coli* ABC133 plasmid pABC133-NDM found in 2012 in the United Arab Emirates (GenBank accession no. KX214671). The genomic environment surrounding *bla*<sub>NDM-12</sub> was *bla*<sub>NDM-12</sub> *ble*<sub>MBL</sub> *trpF* *dsbC* *tnpA* *sull* *qacEdelta1* (type O in Fig. 2). This sequence showed greater than 99.9% identity with the pGUE-NDM plasmid (NCBI accession no. JQ364967) from *E. coli* strain GUE, which was isolated in India, as well as 99.9% identity with the pEC77-NDM plasmid (NCBI accession no. AB898038) from *E. coli* strain NCGM77, which emerged in Japan (14). The genomic environment surrounding *bla*<sub>NDM-13</sub> was *tnpA* IS30 *bla*<sub>NDM-13</sub> *ble*<sub>MBL</sub> *trpF* *dsbC* *cutA* *groES* *groL* (type P in Fig. 2); this sequence has been deposited in GenBank (accession no. LC012596). This structure, except for *bla*<sub>NDM-13</sub>, was identical to that of pPMK1 expressed by *K. pneumoniae* PMK1 (from Nepal) (NCBI accession no. CP008933), the *Enterobacter hormaechei* CCHB10892 plasmid (from Brazil) (accession no. KF727591), pKPX-1 from *K. pneumoniae* KPX (from Taiwan) (accession no. AP012055), and pNDM-MAR isolated from *K. pneumoniae* in Morocco (accession no. JN420336). PFGE and Southern hybridization analyses revealed that *bla*<sub>NDM</sub>s in 19 isolates were found in the plasmids (Fig. S1).

There were no relationships among drug susceptibility profiles, drug resistance genes, MLSTs, and plasmid sizes.

To our knowledge, this is the first molecular epidemiological analysis of carbapenem-resistant *E. coli* clinical isolates in Nepal indicating that the isolates have various types of *bla*<sub>NDM</sub>s. Five isolates belonging to ST648 in clade C were found, despite the lack of isolation of any carbapenem-resistant *E. coli* strain belonging to ST131 in medical settings in Nepal. CTX-M-producing *E. coli* ST131 and ST648 isolates have been reported to cause community-acquired infections in Nepal (15). The dissemination of ST648 *E. coli* isolates in various communities of Nepal appears to be advancing into medical settings, and ST648 *E. coli* isolates are acquiring carbapenem and aminoglycoside resistance.

In conclusion, carbapenem-resistant *E. coli* isolates producing NDMs and 16S rRNA methylases have been spreading in medical settings in Nepal. Gram-negative pathogens producing NDMs and 16S rRNA methylases are resistant to clinically important carbapenems (16) and aminoglycosides (17), respectively. Our previous studies revealed that Gram-negative pathogens, including *Acinetobacter baumannii* (18), *E. coli* (6), *K. pneumoniae* (19), and *Providencia rettgeri* (20), that produce NDMs and 16S rRNA methylases have emerged in medical settings in Nepal. Although this study addressed only carbapenem-resistant *E. coli* isolates, these results suggest the necessity of monitoring the dissemination of both aminoglycoside- and carbapenem-resistant *E. coli* strains in medical settings in Nepal.

This study was reviewed and approved by the Institutional Review Board of the Institute of Medicine at Tribhuvan University (reference no. 6-11-E). The study protocol was carefully reviewed and approved by the ethics committee of the National Center for Global Health and Medicine (reference no. 1268). Individual informed consent was waived by the ethics committee listed above because this study used currently existing samples collected during routine medical care and did not pose any additional risks to the patients. Patient information was anonymized and deidentified prior to the analysis. The study protocol was reviewed and approved by the Biosafety Committee, National Center for Global Health and Medicine (approval no. 28-M-053).

**Nucleotide sequence accession number(s).** The whole-genome sequences of all 38 isolates were deposited in GenBank as accession no. DRA005225 (for the experiment, accession no. DRX069506 to DRX069543; for the run, accession no. DRR075609 to DRR075646).

## SUPPLEMENTAL MATERIAL

Supplemental material for this article may be found at <https://doi.org/10.1128/AAC.01425-17>.

**SUPPLEMENTAL FILE 1**, XLSX file, 0.1 MB.

**SUPPLEMENTAL FILE 2**, XLSX file, 0.1 MB.

**SUPPLEMENTAL FILE 3**, PDF file, 0.1 MB.

## ACKNOWLEDGMENTS

The study was supported by grants from International Health Cooperation Research (29-S-5), JSPS KAKENHI (16K19133), and the Research Program on Emerging and Reemerging Infectious Diseases from AMED.

## REFERENCES

- Bush K. 2001. New  $\beta$ -lactamases in gram-negative bacteria: diversity and impact on the selection of antimicrobial therapy. *Clin Infect Dis* 32: 1085–1089. <https://doi.org/10.1086/319610>.
- Yong D, Toleman MA, Giske CG, Cho HS, Sundman K, Lee K, Walsh TR. 2009. Characterization of a new metallo- $\beta$ -lactamase gene, *bla<sub>NDM-1</sub>*, and a novel erythromycin esterase gene carried on a unique genetic structure in *Klebsiella pneumoniae* sequence type 14 from India. *Antimicrob Agents Chemother* 53:5046–5054. <https://doi.org/10.1128/AAC.00774-09>.
- Cornaglia G, Giamarellou H, Rossolini GM. 2011. Metallo- $\beta$ -lactamases: a last frontier for  $\beta$ -lactams? *Lancet Infect Dis* 11:381–393. [https://doi.org/10.1016/S1473-3099\(11\)70056-1](https://doi.org/10.1016/S1473-3099(11)70056-1).
- Pillai DR, McGeer A, Low DE. 2011. New Delhi metallo- $\beta$ -lactamase-1 in *Enterobacteriaceae*: emerging resistance. *CMAJ* 183:59–64. <https://doi.org/10.1503/cmaj.101487>.
- Islam MA, Talukdar PK, Hoque A, Huq M, Nabi A, Ahmed D, Talukder KA, Pietroni MA, Hays JP, Cravioto A, Endtz HP. 2012. Emergence of multidrug-resistant NDM-1-producing Gram-negative bacteria in Bangladesh. *Eur J Clin Microbiol Infect Dis* 31:2593–2600. <https://doi.org/10.1007/s10096-012-1601-2>.
- Tada T, Miyoshi-Akiyama T, Dahal RK, Sah MK, Ohara H, Kirikae T, Pokhrel BM. 2013. NDM-8 metallo- $\beta$ -lactamase in a multidrug-resistant *Escherichia coli* strain isolated in Nepal. *Antimicrob Agents Chemother* 57: 2394–2396. <https://doi.org/10.1128/AAC.02553-12>.
- Suzuki MT, Taylor LT, DeLong EF. 2000. Quantitative analysis of small-subunit rRNA genes in mixed microbial populations via 5'-nuclease assays. *Appl Environ Microbiol* 66:4605–4614. <https://doi.org/10.1128/AEM.66.11.4605-4614.2000>.
- Clinical Laboratory and Standards Institute. 2015. Methods for dilution antimicrobial susceptibility tests for bacteria that grow aerobically, 10th ed. Document M07-A10. CLSI, Wayne, PA.
- Guindon S, Dufayard JF, Lefort V, Anisimova M, Hordijk W, Gascuel O. 2010. New algorithms and methods to estimate maximum-likelihood phylogenies: assessing the performance of PhyML 3.0. *Syst Biol* 59: 307–321. <https://doi.org/10.1093/sysbio/syq010>.
- Tada T, Shrestha B, Miyoshi-Akiyama T, Shimada K, Ohara H, Kirikae T, Pokhrel BM. 2014. NDM-12, a novel New Delhi metallo- $\beta$ -lactamase variant from a carbapenem-resistant *Escherichia coli* clinical isolate in Nepal. *Antimicrob Agents Chemother* 58:6302–6305. <https://doi.org/10.1128/AAC.03355-14>.
- Clinical Laboratory and Standards Institute. 2015. Performance standards for antimicrobial susceptibility testing; 25th informational supplement. CLSI M100-S25. Clinical and Laboratory Standards Institute, Wayne, PA.
- Wailan AM, Sidjabat HE, Yam WK, Alikhan NF, Petty NK, Sartor AL, Williamson DA, Forde BM, Schembri MA, Beatson SA, Paterson DL, Walsh TR, Partridge SR. 2016. Mechanisms involved in acquisition of *bla<sub>NDM</sub>* genes by IncA/C2 and IncFIIY plasmids. *Antimicrob Agents Chemother* 60:4082–4088. <https://doi.org/10.1128/AAC.00368-16>.
- Bonnin RA, Poirel L, Carattoli A, Nordmann P. 2012. Characterization of an IncFII plasmid encoding NDM-1 from *Escherichia coli* ST131. *PLoS One* 7:e34752. <https://doi.org/10.1371/journal.pone.0034752>.
- Tada T, Miyoshi-Akiyama T, Shimada K, Kirikae T. 2014. Biochemical analysis of the metallo- $\beta$ -lactamase NDM-3 from a multidrug-resistant *Escherichia coli* strain isolated in Japan. *Antimicrob Agents Chemother* 58:3538–3540. <https://doi.org/10.1128/AAC.02793-13>.
- Sherchan JB, Hayakawa K, Miyoshi-Akiyama T, Ohmagari N, Kirikae T, Nagamatsu M, Tojo M, Ohara H, Sherchand JB, Tandukar S. 2015. Clinical epidemiology and molecular analysis of extended-spectrum- $\beta$ -lactamase-producing *Escherichia coli* in Nepal: characteristics of sequence types 131 and 648. *Antimicrob Agents Chemother* 59:3424–3432. <https://doi.org/10.1128/AAC.00270-15>.
- Queenan AM, Bush K. 2007. Carbapenemases: the versatile  $\beta$ -lactamases. *Clin Microbiol Rev* 20:440–458. <https://doi.org/10.1128/CMR.00001-07>.
- Wachino J, Arakawa Y. 2012. Exogenously acquired 16S rRNA methyltransferases found in aminoglycoside-resistant pathogenic Gram-negative bacteria: an update. *Drug Resist Updat* 15:133–148. <https://doi.org/10.1016/j.drug.2012.05.001>.
- Shrestha S, Tada T, Miyoshi-Akiyama T, Ohara H, Shimada K, Satou K, Teruya K, Nakano K, Shiroma A, Sherchand JB, Rijal BP, Hirano T, Kirikae T, Pokhrel BM. 2015. Molecular epidemiology of multidrug-resistant *Acinetobacter baumannii* isolates in a university hospital in Nepal reveals the emergence of a novel epidemic clonal lineage. *Int J Antimicrob Agents* 46:526–531. <https://doi.org/10.1016/j.ijantimicag.2015.07.012>.
- Tada T, Miyoshi-Akiyama T, Dahal RK, Mishra SK, Ohara H, Shimada K, Kirikae T, Pokhrel BM. 2013. Dissemination of multidrug-resistant *Klebsiella pneumoniae* clinical isolates with various combinations of carbapenemases (NDM-1 and OXA-72) and 16S rRNA methylases (ArmA, RmtC and RmtF) in Nepal. *Int J Antimicrob Agents* 42:372–374. <https://doi.org/10.1016/j.ijantimicag.2013.06.014>.
- Tada T, Miyoshi-Akiyama T, Dahal RK, Sah MK, Ohara H, Shimada K, Kirikae T, Pokhrel BM. 2014. NDM-1 metallo- $\beta$ -lactamase and ArmA 16S rRNA methylase producing *Providencia rettgeri* clinical isolates in Nepal. *BMC Infect Dis* 14:56. <https://doi.org/10.1186/1471-2334-14-56>.

**Contact details for further information**

**Hiroshi OHARA, M.D., Ph.D.**

Bureau of International Health Cooperation, Japan  
National Center for Global Health and Medicine, Japan  
Email: [oharah@it.ncgm.go.jp](mailto:oharah@it.ncgm.go.jp)

**Annual Report 2016-2017**

IOM-NCGM Research Collaboration Office

© National Center for Global Health and Medicine, Japan  
All rights reserved.

National Center for Global Health and Medicine, Japan  
Bureau of International Health Cooperation, Japan  
1-21-1 Toyama, Shinjuku-ku, Tokyo 162-8655  
Tel: +81-3-3202-7181 / Fax: +81-3-3205-6780  
[info@it.ncgm.go.jp](mailto:info@it.ncgm.go.jp)





**Research Collaboration Office**

Institute of Medicine, Tribhuvan University, Kathmandu, Nepal

National Center for Global Health and Medicine, Tokyo, Japan

